



CREST

Owner's Manual

2025



A SAFE OPERATOR IS AN INFORMED OPERATOR

Every person who operates your Crest pontoon should be familiar with the contents of this manual before taking the boat out on the water.

- Always follow safe boating practices when operating your Crest pontoon.
- Never operate your boat while under the influence of alcohol or drugs.
- Remain seated in designated seating areas while the boat is underway.
- Never ride on the foredeck or the rear sundeck.

This manual has been compiled to help you operate your boat with safety and pleasure. It contains details of the boat, the equipment supplied or fitted, its systems, and information on its operation and maintenance. Please read it carefully and familiarize yourself with the boat before using it.

If this is your first boat, or if you are changing to a type of boat you are not familiar with, for your own comfort and safety, please ensure that you obtain handling and operating experience before "assuming command" of the boat. Your dealer or national sailing federation or yacht club will be pleased to advise you of local sea schools or competent instructors.

PLEASE KEEP THIS MANUAL IN A SECURE PLACE, AND HAND IT OVER TO THE NEW OWNER WHEN YOU SELL THE BOAT.

Because we have a policy of continuous product improvement, the illustrations used in this manual may not be the same as your boat and are intended as representative reference views. Some controls, indicators, or information may be optional and not included on your boat.

Your dealer may have installed equipment such as an outboard motor, trolling motor and battery, and additional canvas. Although Crest Marine has provided guidance and recommendations for dealer-installed equipment, we have no control over the dealer's selection or methods of installation. Please refer any questions regarding dealer-installed equipment to your dealer.

Table of Contents

1 INTRODUCTION	1.1
Hazard Communication Statements	1.2
Owner Advisory Statements	1.3
Protecting the Environment	1.3
General Information	1.3
Boat Delivery Responsibilities	1.5
Equipment Manufacturer Manuals	1.6
Owner Responsibilities	1.6
Boating Laws and Regulations	1.7
Hazard Communication Labels	1.8
Boat Data Sheet	1.9
Service/Maintenance Log	1.10
Limited Warranty Statement	1.11
2 SAFETY	2.1
Safe Boating Recommendations	2.1
Safety Gear and Equipment	2.2
Safe Boating Practices	2.6
Carbon Monoxide	2.8
Lanyard Stop Switch	2.12
Water Sports	2.13
3 SYSTEMS AND COMPONENTS	3.1
Electrical System	3.1
Instruments	3.4
Controls	3.6
Trolling Motor	3.8
Livewell	3.8
Canvas	3.10
Audio Systems	3.10
4 TRAILERING	4.1
Trailer	4.1
Hitch	4.2
Safety Chains	4.3
Trailer Guidelines	4.4
Backing a Trailer	4.5
Launching Guidelines	4.6
Loading Your Boat on the Trailer	4.7
5 UNDERWAY	5.1
Boater's Checklist	5.1
Fueling	5.2
Loading Passengers and Gear	5.4
Boarding	5.5
Reboarding	5.5

Layouts and Seating	5.6
Starting the Engine	5.7
Leaving the Dock	5.8
Steering	5.9
Boat Speed	5.10
General Rules of Seamanship	5.13
Stopping	5.13
Anchoring	5.14
Docking	5.15
Mooring	5.15
Pontoon Hoists and Lifts	5.16
Emergency Operation	5.17
6 CARING FOR YOUR BOAT	6.1
Engine	6.1
Aluminum Surfaces	6.1
Pontoons	6.3
Saltwater Use	6.3
Deck Coverings	6.3
Deck Hardware and Fittings	6.4
Seat Coverings and Vinyl	6.4
Vinyl Upholstery Cleaning and Care Instructions	6.5
Mooring and Furniture Coverings	6.5
Canvas	6.6
Floor Coverings	6.6
Fiberglass	6.7
Pontoon Maintenance	6.7
7 WINTERIZATION AND STORAGE	7.1
Preparation for Storage	7.1
Supporting Your Boat During Storage	7.3
Fitting Out After Storage	7.3
8 HELPFUL INFORMATION	8.1
Boating Regulations	8.1
Rules of Seamanship	8.1
Recommended Reading	8.5
Contacts	8.5
Navigational Aids	8.6
Navigational Aids Chart	8.8
9 BOATING TERMINOLOGY	9.1
10 WARRANTY TRANSFER	10.1

Introduction

Please take the time to read this manual before you take your boat out for the first time. Also, read all literature supplied with your boat by the manufacturers of the various components and accessories used on your boat. In particular, you want to become familiar with operating your engine.

If you are a novice boater, you may not be familiar with the terms experienced boaters use. Figure 1.1 will help you. It lists some common terms and how they apply to a typical boat.

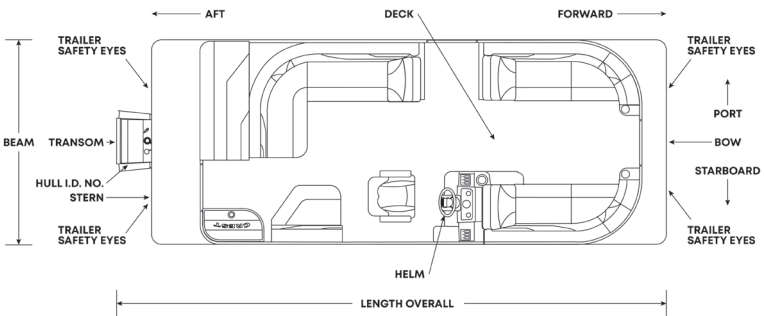

FIGURE 1-1 TERMINOLOGY

Before your first boating excursion, look your boat over and become familiar with it. Find its components, gauges, and operating equipment; and learn how to use them. You should also know your boat's length and height.

If a family member or friend operates your boat, be sure he or she fully understands the controls and operation of the boat. Each boat operator is responsible for ensuring the safety of the boat's passengers and other water users. Passengers should also be aware that courteous, responsible riding is important.

This manual is part of your boat's equipment. It does not supersede or change any of the original manufacturers' specifications, operation or maintenance instructions. Always keep it on board. If you transfer ownership of this boat to someone else, be sure to give this manual to the new owner.

HAZARD COMMUNICATION STATEMENTS

Three types of hazard communication statements used throughout this manual call attention to special information to help avoid dangerous situations and operate your boat safely.



Watch for the safety alert symbol. It means pay attention! Your safety is involved! Failure to follow the recommendations in a hazard communication statement may result in property damage, personal injury, or death.

The signal words **DANGER**, **WARNING** and **CAUTION** identify hazards and the levels of hazard seriousness. Their selection is based on the likely consequence of human interaction with a hazard in terms of the probability of injury and the degree of severity. Failure to follow the recommendations contained in any of these statements may result in some form of personal injury. Definitions for identifying hazard levels with their respective signal words are listed below.



Immediate hazards that **WILL** result in severe personal injury or death.



Hazards or unsafe practices that **COULD** result in severe personal injury or death.



Hazards or unsafe practices that **COULD** result in minor personal injury or product or property damage.

OWNER ADVISORY STATEMENTS

Advisory statements alert you to conditions that affect equipment operation, maintenance, and servicing practices.

An **IMPORTANT** statement indicates a procedure intended to prevent damage to equipment or associated components.

A **Note** is a general advisory statement relating to equipment operation and maintenance procedures.

PROTECTING THE ENVIRONMENT

It's fun to be out on the water whether you're fishing, cruising, or just soaking up the sun. Unfortunately, not all boaters are responsible individuals, and their foolish actions often spoil our waterways. Here are seven ways you can help protect the aquatic environment as recommended by the National Marine Manufacturers Association. Practice them every time you go out, and you can help ensure that our waterways will remain clean and unspoiled for years to come.

- Observe local and federal marine head rules.
- Know about and use legal bottom paints.
- Use biodegradable cleaning agents whenever possible.
- Don't litter on or off the water—take it home!
- Don't top off fuel tanks, and always clean up fuel spills.
- Watch your wake and propeller wash.
- Keep your motors finely tuned.

GENERAL INFORMATION

This section of your boat manual contains important information about your Crest pontoon and general procedures to be followed before operating it.

A Word About Crest Pontoons

Some Crest pontoons have three pontoons instead of two. We call these boats "tritoons." The third pontoon will change the way the boat handles, and it will increase the boat's weight capacity. It also provides exceptional lift, delivers a higher ride, and distributes rough-water stress more evenly.

You are responsible for using common sense and sound judgment when loading your boat. Give yourself an added

margin for safety in turbulent waters. Pontoon boats tend to remain stable under most operating conditions. Remember that overloading and improper distribution of weight are significant causes of accidents. Keep weight below maximum limits for safety in turbulent waters. Overloading is a violation of U.S. Coast Guard regulations.



Do not exceed your boat's capacity rating. An overpowered boat can become unstable, resulting in a loss of control or capsizing. An overloaded boat can become hard to handle. Overloading can also reduce freeboard and increase the danger of flooding or swamping, particularly in rough water.

IMPORTANT: Your warranty will be voided if you exceed the recommended capacity ratings.

Hull Identification Number

Along with a capacity plate, each Crest pontoon has a hull identification number. The number on your pontoon boat is either on the starboard side of the transom or on the inside of the M bracket close to the rear starboard pontoon. The number will begin with CSM.

For example: CSM00000A000
(CSM followed by 5 digits, 1 letter, 3 digits)

Owner's Logs and Records

At the end of this chapter are two forms you will find very helpful.

Use the Boat Data Record to record all important information about your boat and the major components installed. After you have entered all the data, remove this form from your Owner's Manual and store in a safe place. Do not keep this form aboard your boat.

The Service/Maintenance Log provides a record of maintenance work completed on your boat, the date of completion, and the number of hours on the engine at that point in time. This log also helps you identify the frequency of routine maintenance work, such as engine oil changes. If you should decide to sell your boat, it demonstrates to prospective buyers that you have done a good job of taking care of your boat.

Education

Courses on boat handling and seamanship are conducted by volunteer organizations, such as the U.S. Power Squadrons, the U.S. Coast Guard Auxiliary, and the American Red Cross. These courses will sharpen your boating skills and bring you up-to-date on current rules and regulations even if you are a veteran boater. See Chapter 8 for more information.

BOAT DELIVERY RESPONSIBILITIES

When you take delivery of your boat, both you and your dealer have specific responsibilities.

Dealer

The dealer is responsible for:

1. Discussing the terms of all warranties, and stressing the importance of registering warranties with the appropriate manufacturers.
2. Providing instruction for obtaining warranty service.
3. Going over the pre-delivery service record with you, and then signing it to certify that all work has been done.
4. Giving you thorough instruction on how to operate your boat and all of its systems and components.
5. Completing the warranty registration in the DMS.

Owner

As the owner, you are responsible for:

1. Signing off on the boat inspection sheet before delivery.
2. Scheduling an appointment with your dealer to go over all warranties. Helping the dealer complete the registration card and checking that the dealer has submitted the warranty into the factory within 10 days of the date of purchase.
3. Keeping a record of the hull number for future reference.
4. Inspecting the boat at the time of delivery to ensure that all systems and components are working properly.
5. Scheduling an appointment with your dealer to go over the pre-delivery engine service record. Signing this record to indicate that your dealer has explained this to you.
6. Operating all equipment in accordance with the manufacturer's instructions. Reading all manuals and

instructions supplied with your boat.

7. Referring to your engine warranty for initial inspection and service requirements.
8. Performing the appropriate periodic maintenance outlined in the owner's manuals and service guides.
9. Being a safe boater. Crest recommends that all boaters take safe boating courses.

EQUIPMENT MANUFACTURER MANUALS

Most OEMs (original equipment manufacturers) have also provided operation and maintenance manuals for your boat's equipment. Keep the OEM manuals with your Owner's Manual in a safe and accessible place. Pass them along to the new owner if you sell your boat.

Please note that, in some cases, information in this manual only summarizes more detailed information in the equipment manuals. Information in the OEM manuals takes precedence over information in this Owner's Manual.

OWNER RESPONSIBILITIES

Boating is an enjoyable and relaxing leisure time activity. Personal responsibility is also a part of boating. You are responsible for:

- Registering your boat with state authorities.
- Providing adequate insurance.
- Obeying the rules of the road.
- Maintaining your boat and its equipment.
- Acquiring and maintaining safety equipment.
- Safety training of passengers and crew.
- Understanding the operation of boat systems and equipment.
- Making seaworthiness/operational inspections.
- Operating your boat safely.
- Avoiding the use of alcohol and drugs.
- Complying with environmental regulations.
- Filing accident reports, if necessary.

Crest recommends that all boaters take safe boating

courses. We also believe that boaters have one more major responsibility—the environment. While you're out on the water, keep in mind the future of our waterways and the marine life that lives in these waters. Do everything you can to preserve the natural habitats we still have. Keep them free of garbage and debris. Preserving our waterways and habitats now can help ensure the pleasure of boating for others for years to come.

BOATING LAWS AND REGULATIONS

Boat Registration

All motorcraft not documented by the U.S. Coast Guard must display registration numbers. Every boat equipped with propulsion machinery of any type must be registered in the main state of usage. In nearly all states this means registration with the designated state agency. In a few jurisdictions, the Coast Guard retains registration authority. Registration numbers and validation stickers must be displayed on the boat according to regulations. Your Crest dealer will either supply registration forms or tell you where they may be obtained. The registration agency will issue a certificate which must be aboard when using your new Crest pontoon.

Some states and localities have limits in speed, noise, and trailer specifications. It is your responsibility to be aware of these laws and limits and to be sure that your boat (and trailer) complies. Consult with your local sheriff marine patrol, local Coast Guard office, or state Department of Natural Resources.

Insurance

The boat owner is legally responsible for any damages or injuries caused by the boat. In most states this is true even if someone else is operating the boat when the accident occurs. You should carry adequate personal liability and property damage insurance on your boat as you do on your automobile. You should also protect your investment by insuring your boat against physical damage or theft.

Discharge of Oil

The Federal Water Pollution Control Act prohibits the discharge of oil or oily waste into or upon the navigable waters of the United States or the waters of the contiguous zone, if such discharge causes a film or sheen upon or a discoloration of the surface of the water or causes a sludge or emulsion beneath the surface of the water. Violators are subject to a penalty of \$5,000.

Disposal of Plastics & Other Garbage

Plastic refuse dumped in the water can kill fish and marine wildlife and can foul propellers and water intakes. Other forms of waterborne garbage can litter beaches and make people sick. U.S. Coast Guard regulations completely prohibit the dumping of plastic refuse or other garbage mixed with plastic anywhere, and restrict the dumping of other forms of garbage within specified distances from shore. Proper disposal of garbage helps protect our waterways and marine life.

HAZARD COMMUNICATION LABELS

Some or all of the hazard communication labels shown below can be found in various locations on board your boat. The labels appropriate for your boat are determined by the standard and optional equipment actually installed on board your boat upon delivery. Check with your dealer to find out what labels your boat should have. If any label is missing, ask your dealer for a replacement.

IMPORTANT: The purpose of these labels is to prevent accidents, injury, or death. Make sure everyone on board reads and understands them!

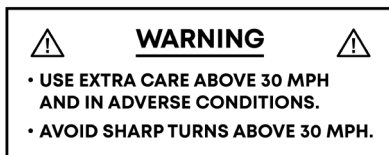
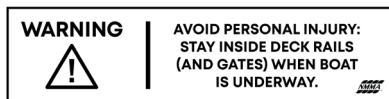
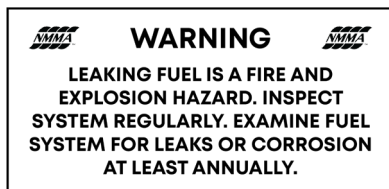

BOAT DATA SHEET

Model Name _____

Hull Identification Number _____

Length _____ Beam _____ Weight _____

Draft (Down) _____ Draft (Up) _____

Engine

Make _____ Model Name _____

Horsepower _____ Model No. _____

Serial No. _____

Fuel Tank Capacity _____ Fuel Filter No. _____

Radio

Make _____ Type _____

Model No. _____ Serial No. _____

Battery Make _____ Type _____

Propeller(s) Manufacturer _____

Diameter/Pitch _____ / _____ No. of Blades _____

Style _____ Material _____

Mfg. Part. No. _____ Key Numbers _____

Glove Box _____ Ignition Switch _____

Other Equipment

Selling Dealer

Name _____

Address _____

Phone No. _____

Salesman _____

Servicing Dealer

Name _____

Address _____

Phone No. _____

Service Manager _____

SERVICE/MAINTENANCE LOG

DATE	ENGINE HOURS	SERVICE/REPAIRS PERFORMED

LIMITED WARRANTY STATEMENT

(Effective beginning with the 2025 model year) Crest Marine, LLC

1. Disclaimer and Limitation of Implied Warranties

The express limited warranty set forth herein (this "Warranty", "Limited Warranty" or the "Limited Warranty Statement") is in lieu of all other warranties and representations, express or implied, and to the maximum extent permitted by applicable law, Crest Marine, LLC ("Crest") the manufacturer and producer of various lines and models of pontoon boats under the Crest™ brand name, hereby disclaims, and the Purchaser (as defined in Section 2) hereby expressly waives, any and all other warranties or representations of any kind or nature, including, but not limited to, implied warranties of merchantability and fitness for a particular purpose, other than those warranties which are implied by, and are incapable of exclusion, restriction or modification under applicable law. The term of any implied warranties that cannot be disclaimed under applicable law, including, but not limited to, implied warranties of merchantability and fitness for a particular purpose, shall be limited to the duration of the express warranty periods applicable to the respective components. Some states do not allow the exclusion of implied warranties and/or do not allow limitations on the amount of time an implied warranty lasts, so the above limitations may not apply to you. This Limited Warranty gives you specific legal rights. You may have other rights which vary from state to state.

2. Limited Warranty Coverage & Term

Subject to the conditions, limitations and exclusions set forth in Section 3 of the Limited Warranty, Crest warrants only to the original retail purchaser (the "Purchaser" or "You") that the following components of each new and unused Crest boat shall be free from material defects in materials and workmanship to the extent set forth in this warranty, under normal use and when operated and maintained in accordance with Crest's instructions, beginning on the Start Date defined in Section 2.5 of this Limited Warranty Statement, for the period(s) indicated in this Section 2:

2.1 Limited Lifetime Warranty on Structural Components.

The pontoons, under deck, wooden deck, motor mounts, transom, gates, railings, and wood structural components (collectively, the "Structural Components" of the boat) are warranted for as long as the original Purchaser owns the boat. For properly completed warranty transfers to a second

owner of the boat in accordance with Section 6 of this Limited Warranty, this warranty for Structural Components is limited to a total of ten (10) years from the Start Date.

2.2 Limited 10-Year Warranty on Certain Components.

Crest warrants each of the following components for a period of ten (10) years from the Start Date:

- (a) Floor coverings;
- (b) Fiberglass components;
- (c) Seating upholstery, other fabrics and mooring covers; and
- (d) Other components not excluded in Section 3 of this Warranty.

2.3 Gel Coat. Provided that the Purchaser has provided proper maintenance and care as described in the Crest Owner's Manual, the gel coat on any fiberglass parts which is applied at Crest's factory will be warranted for a period of three (3) years from the Start Date for stress crazing of the gel coat.

2.4 Powder Coated Components. The powder coating on the pontoons and certain other components of your Crest boat is warranted for a period of five (5) years from the Start Date.

2.5 Warranty Period. All express warranties are for the applicable time periods set forth in this Section 2, unless a longer warranty period is required by applicable law, in which case such longer warranty period will apply. Crest boats are manufactured in model years which run from June 1st of a given year through May 31st of the immediately following year (a "Model Year"). The start date for the warranty periods shall be deemed to be the earlier of the date of the original retail purchase of the new and unused boat or trailer from an authorized Crest dealer, as applicable, or the date that the boat was first used by Purchaser, whichever first occurs (the "Start Date"). The manufacturers of certain components of your Crest boat warrant their product for periods exceeding the time limits stated in this Limited Warranty Statement. Crest administers this Warranty within the limits specified in this Limited Warranty Statement only but will provide contact information to you from component manufacturers in applicable circumstances to consumers upon your request.

3. Warranty Conditions, Limitations and Exclusions

Crest boats are manufactured by trained crafts-persons from high-quality materials and components. However, conditions

outside of Crest's control require specific limitations on, and exclusions from, coverage under this Warranty. The Warranty on the Structural Components set forth in Section 2.1 of this Warranty does not cover or include any other components fastened or applied to any of the Structural Components. This Limited Warranty constitutes the final, complete and exclusive statement of warranty terms, and no other person or entity is authorized to make any other warranties or representations on behalf of Crest regarding any Crest product. Furthermore, the warranty set forth in Section 2 (including all subsections) of this Limited Warranty Statement does NOT cover any of the following, each of which are expressly excluded from warranty coverage:

(a) All Engine(s) on your Crest boat. Warranties for your engines and related components on your Crest boat are provided by the engine manufacturer.

(b) All screens and electronic equipment. Warranties for the screens and electronic equipment and components on your Crest boat are provided by the equipment manufacturers.

(c) Crest also does not provide any warranty for any other equipment, components or accessories for which the manufacturer of such items provides their own limited product warranties and/or which are not installed on your boat by Crest (e.g., trailers, propellers, batteries, etc.). Crest does not supplement the warranties provided by the manufacturers of any of the products described in subsections (a), (b) or (c) of this Section 3. In the event you have any questions regarding the warranties provided by the manufacturers of any of these components, Crest will provide you with applicable warranty information regarding those components from the manufacturer of that equipment.

(d) Damage caused by misuse, negligence, accident, collision or impact with any object. Use of a Crest boat powered or loaded in excess of maximum limits as stated on the U.S. Coast Guard Capacity Plate in each boat, is a misuse of the boat.

(e) Damage caused by any improper alteration or modification to the boat or any of its component parts or accessories, including damage resulting from alteration, modification, repair or replacement in such a way as to increase the cubic-inch capacity or horsepower output of the engine and boat as originally manufactured.

(f) Damage caused by the use of improper or contaminated fuel or fluids.

- (g)** Damage caused by the use of customer-applied chemicals or accidental spills.
- (h)** Damage caused by failure to maintain the boat in accordance with the maintenance provisions in the Owner's Manual or on Crest's website, or the improper maintenance of, or repairs to, the boat by a service facility, Purchaser, or any other person or entity.
- (i)** Damage caused by the failure to comply with any recall or request for repair as directed by Crest.
- (j)** Use of the boat for rental, commercial or industrial purposes.
- (k)** Damage to hardware and other components fastened or adhered to the Structural Components or any other components of the boat.
- (l)** Damage caused by fire, theft, freezing, vandalism, explosion, lightning, wind, hail storms, flooding or any other type of natural disaster, weather event or Acts of God.
- (m)** Damage caused by use of a trailer to transport, move or store the boat.
- (n)** Damage caused by improper support of the boat on davits, a hoist system or boat lift of any kind, improper trailer or mismatching of the boat to a trailer, failure to properly secure the boat to a trailer, or failure to properly use a support device when trailering the boat.
- (o)** Damage to, failure or other problems with paints, varnishes, gel coat surfaces and colors (except with regard to the limited warranty for gel coat provided in Section 2.3 hereof), chrome-plated or anodized finishes, floor and floor covers (such as rips or tears caused by the actions of Purchaser or others) and any other surface coatings, fading of any such surfaces from sun exposure and/or fading of, or mold on, upholstery, mooring covers, or toping materials such as Bimini covers, etc.
- (p)** Damage due to in-water storage without proper barrier coat and bottom paints or any other type of corrosion due to any type of water condition or use in salt water or brackish water. A proper barrier coat and bottom paint should be used whenever it is anticipated that the boat will be left in the water for an extended period of time, i.e., in excess of thirty (30) days.
- (q)** No warranty is provided, and Crest expressly disclaims, any warranty for scratching, discoloration or fading of gel coat on any fiberglass components of the boat. The reason

for this limitation and exclusion is because environmental operating conditions and customer maintenance/care are factors that have a significant effect on the condition and durability of the gel coat and are factors that are outside of Crest's reasonable control.

(r) Damage due to installation of, or the removal and/or de-rigging of, engines or other accessories not performed by Crest or one of its authorized dealers.

(s) Damage caused by dealer-installed or Purchaser-installed options or accessories.

(t) Damage caused by any type of pet or animal.

(u) All standard maintenance items that wear with use and must be periodically replaced or replenished, including but not limited to:

1. Batteries;
2. Light bulbs;
3. Fuses;
4. Gaskets, foam and padding.

4. Commercial Use

4.1 Definition. For purposes of this warranty, a Commercial Boat is defined as a boat that is used to generate income of any kind, whether direct or indirect. Examples of boats used for commercial purposes include those used as rental boats, boats used in boat clubs or resorts, or boats made available in boat sharing platforms (e.g., Boatsetter, etc.).

4.2 Warranty Conditions, Limitations and Exclusions.

In addition to the warranty conditions, limitations and exclusions, set forth in Section 3 of this Limited Warranty, all of which apply to Commercial Boats, the following additional warranty limitations apply to Commercial Boats:

(a) Crest will provide full warranty coverage for Structural Components and all other components described in Sections 2.2, 2.3 and 2.4 of this Warranty in accordance with the terms and conditions of this Limited Warranty Statement a period of one (1) year from the Start Date.

(b) Upon sale of the boat by Purchaser to a second owner, all warranty coverage under this Limited Warranty Statement shall expire and be of no further force or effect.

5. Limitation of Liability

5.1 Liability Limitation: Exclusion of Consequential Damages. This Limited Warranty is for the benefit of the Purchaser and Crest regarding Crest products and shall not create or evidence any right in any third party. The repair or replacement of any component parts as provided under this Warranty is the exclusive remedy of the Purchaser. The decision regarding whether a part or component should be repaired or replaced will be made by the Crest authorized dealer and/or by Crest. TO THE MAXIMUM EXTENT PERMITTED BY APPLICABLE LAW, IN NO EVENT SHALL CREST BE LIABLE FOR ANY INCIDENTAL, CONSEQUENTIAL, SPECIAL, INDIRECT, PUNITIVE OR EXEMPLARY DAMAGES OR LOST PROFITS, LOSS OF VACATION OR PERSONAL TIME, TRAVEL-RELATED EXPENSES, OR THE LIKE WHATSOEVER ARISING OUT OF THE USE OR INABILITY TO USE YOUR CREST BOAT OR ANY COMPONENT PART THEREOF, OR FOR ANY BREACH OF THIS LIMITED WARRANTY OR OTHERWISE, EVEN IF CREST HAS BEEN ADVISED OF THE POSSIBILITY OF SUCH DAMAGES OR SUCH DAMAGES COULD REASONABLY HAVE BEEN FORESEEN BY CREST. However, some states do not allow the exclusion or limitation of incidental or consequential damages, so the above limitation or exclusion may not apply to you.

5.2 Purchase Price Limitation. In any event, Crest's entire liability under any provision of this Limited Warranty shall be limited to the repair or replacement of the boat or component part, or the refund of the purchase price paid by the Purchaser for the boat or component part found to be defective within the applicable warranty period. This shall constitute Crest's sole liability and obligation in the event of any claim arising out of its performance or nonperformance of any provision of this Limited Warranty. Because some states and jurisdictions do not allow the exclusion or limitation of liability, the above limitations may not apply to you.

6. Transfer of Limited Warranty

Subject to the provisions of Section 4 and this Section 6, and the conditions, limitations and exclusions of Section 3, of this Limited Warranty, upon the first sale, conveyance or other transfer of the boat by the original retail Purchaser any remaining unexpired warranty coverage under Sections 2 or 4 of this Limited Warranty, as applicable, shall be transferred to the second owner and shall remain in effect for the remainder of the applicable warranty period(s) set forth herein (which

warranty periods begin to run in accordance with Section 2 or Section 4.2(a) hereof, as applicable). Such transfer will not be effective until delivery of the completed warranty transfer form, payment of the applicable warranty transfer fee to an authorized dealer of Crest, and delivery of the Crest boat to the Crest dealer for an inspection as described in this Section 6.

With respect to the Lifetime Limited Warranty (granted only to the original retail Purchaser) on the Structural Components set forth in Section 2.1 hereof, if: (a) the sale, conveyance or other transfer of the Crest boat by the original retail purchaser to another person or entity occurs within ten (10) years of the date of the Start Date (as defined in Section 2.4 hereof); AND (b) the original retail purchaser and the second owner comply with the provisions of this Section 6, then the Limited Warranty on the Structural Components shall be transferred to the second owner and shall continue in effect for the remainder of the ten (10) year warranty period which began on the Start Date.

Only one (1) transfer of the Limited Warranty under the provisions of this Section 6 (from the original retail Purchaser to the second owner), within the applicable time period, may be made.

In the event of a sale or transfer of the boat and/or trailer by a second owner to a subsequent purchaser, all coverage under this Limited Warranty shall immediately be terminated and the Limited Warranty shall immediately become null and void. No transfer of this Limited Warranty will operate to extend any of the warranty periods set forth in Sections 2 or 4 hereof.

In order to effectuate the transfer of the Limited Warranty, the original retail Purchaser and the new owner must properly fill out the warranty transfer form designated by Crest and must: (i) deliver the completed transfer form and a copy of the sales agreement/bill of sale between the original retail Purchaser and the second owner; (ii) pay the warranty transfer fee in the amount of \$500; and (iii) deliver the Crest boat for inspection; to an authorized dealer of Crest. The delivery of the form and payment of the warranty transfer fee must be made within the time period specified above in this Section 6 in order for the warranty transfer from the original retail purchaser to the second owner to be effective. **Additionally, the original retail Purchaser and/or the new owner must transport the Crest boat to an authorized Crest dealer for the completion of an inspection to be documented on a Condition Report which shall be submitted to Crest by the authorized dealer.** The inspection is to be completed at a cost determined by the Crest dealer, which cost shall be the responsibility of the new owner.

See details for engine warranty transfer procedure in the engine manufacturer's Owner's Manual or other materials, where applicable.

7. Warranty Claims

In order to maintain warranty service under this Warranty, the Purchaser must return the defective boat or component part to an authorized Crest dealer's service department within the applicable warranty period. For questions regarding warranty service or to obtain information regarding warranty service or to obtain information regarding the nearest authorized Crest dealer, you can contact Crest at the following address or telephone number:

Crest Marine, LLC
Attention: Crest Warranty/Customer Service
2710 M-52
Owosso, Michigan 48867
(989) 725-5188

Subject to the terms of this Limited Warranty, any covered boat or component part with a material defect in materials or workmanship that is returned to an authorized Crest Dealer's service department during the appropriate warranty period will be repaired or replaced, in Crest's sole discretion, without charge to the owner for parts and labor. This provision is subject to the following terms and conditions:

1. Crest shall be obligated only to repair or replace those items that prove defective, in Crest's sole discretion, upon examination by a Crest authorized dealer's service department or Crest's own personnel, as applicable. If it appears that the problem is within the terms of this Limited Warranty, the Crest dealer will repair, or have repaired, all defective parts found to be under warranty. Any repairs performed by a Crest dealer must receive prior written authorization from Crest unless otherwise stated.
2. Crest warrants the repairs or replacements on all Crest products only for the remainder of the applicable warranty period under the terms of this Limited Warranty.
3. Crest shall, in its sole discretion, fulfill its obligation to repair or replace any defective item an authorized Crest dealer's service department or at Crest's factory, in Crest's sole discretion.
4. The Purchaser shall be responsible for all costs associated with the transportation of the boat, towing bills, trailer or

component part(s) to the authorized Crest dealer's service department or Crest's manufacturing facility, as applicable, and for any return transportation.

8. No Modification of Warranty

No oral or written information, advice or communication of any nature to or from Crest or its representatives, employees, authorized dealers, agents, distributors or suppliers shall create a warranty or in any manner increase or modify the scope of this Limited Warranty in any manner whatsoever.

9. Modification of Products

Crest seeks to continuously improve its products. Therefore, Crest has, and reserves, the unlimited right to modify, improve, alter or discontinue the design, specifications, features and/or models of its Crest boats and any other products at any time and from time to time, in its sole and absolute discretion, and Crest will not be obligated to make any such changes in any Crest boats previously manufactured by Crest.

10. Severability

All terms of this Limited Warranty are severable, and the invalidity or unenforceability of any portion hereof shall not affect the validity or enforceability of the remaining provision of this Warranty.

TMCrest is a trademark of Crest Marine, LLC. All rights reserved.
Effective: June 1, 2024

Safety

You should fully understand and become familiar with the operating procedures and safety precautions in this manual and the other information in the owner's packet before you launch your boat. Remember: "Safe boating is no accident." Always operate your boat with consideration, courtesy, and common sense.

Before leaving on your boating excursion, be sure that all required safety equipment is on board. This includes the minimum required equipment and additional gear needed for your excursion. Periodically inspect all safety equipment to be sure it is in proper operating condition. Make sure all passengers know what safety equipment is on board, where it is, and how to use it.

SAFE BOATING RECOMMENDATIONS

Boating safety and the safety of your passengers is YOUR responsibility. You should fully understand all of the following safety precautions before you launch your boat.

- Never operate a boat while under the influence of drugs or alcohol. Doing so is a Federal offense. Make sure only qualified drivers operate your boat.
- Keep your boat and equipment in safe operating condition. Inspect the boat, engine(s), safety equipment, and all boating gear regularly.
- Be sure lifesaving and fire extinguishing equipment is on board. This equipment must meet regulatory standards, and it should be noticeable, accessible, and in safe operating condition. Your passengers should know where this equipment is and how to use it.
- Always keep accurate, updated navigation charts of the area on board.
- Before you leave shore, tell a family member, relative, friend, or other responsible person ashore where you are going and when you expect to return.
- Do not allow passengers to ride on parts of your boat other than designated seating areas. All passengers should remain seated while the boat is moving.

- Understand and obey the “Rules of the Road.” Always maintain complete control of your boat.
- Do not overload or improperly load your boat. The capacity plate is a guide. You must use good judgment. The capacity of your boat is reduced by turbulent water and other adverse weather conditions. Check water and weather conditions before getting underway.

SAFETY GEAR AND EQUIPMENT

As the owner of the boat, you are responsible for supplying all required safety equipment. Check state and local regulations and call the U.S. Coast Guard Boating Safety Hotline at 1-800-368-5647 for information about required safety equipment. You should also consider supplying additional equipment recommended for your safety and that of your passengers. A list of this equipment appears later in this chapter.

U.S. Coast Guard website: www.uscgboating.org

Required Gear and Equipment

Most safety equipment required by federal regulations is provided as standard equipment on your boat. However, you are responsible for obtaining required safety equipment approved by the U.S. Coast Guard if it is not provided. Minimum requirements include the following:

- Personal Flotation Devices (PFD)
- Fire Extinguisher
- Visual Distress Signal
- Navigation Lights
- Horn (All Crest pontoons are equipped with a horn that satisfies this requirement.)

Personal Flotation Devices

You are required by Federal Regulations to have at least one Coast Guard approved personal flotation device for each person in your boat. You may not use your recreational boat unless all your PFDs are in serviceable condition, are readily accessible, legibly marked with the Coast Guard approval number, and are of an appropriate size (within the weight range and chest size marked on the PFD) for each person on board. Your PFD provides buoyancy to help keep your head above the water and to help you remain in a satisfactory position while in the water.

PFD Type I, Wearable (Figure 2-1) has the greatest required buoyancy. Its design allows for turning most unconscious persons in the water from face down position to a vertical or slightly backward, face-up position. Type I is most effective for all waters, especially offshore when rescue may be delayed.

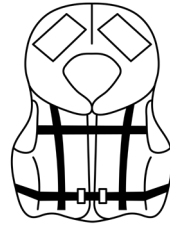

FIGURE 2-1 PFD TYPE 1, WEARABLE

PFD Type II, Wearable (Figure 2-2) turns its wearer in the same way as Type I, but not as effectively. The Type II will not turn as many persons under the same conditions as a Type I.

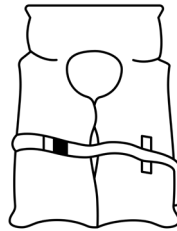

FIGURE 2-2 PFD TYPE 2, WEARABLE

PFD Type III, Wearable (Figure 2-3) allows the wearers to place themselves in a vertical or slightly backward position. It has the same buoyancy as a Type II PFD. It has little or no turning ability.

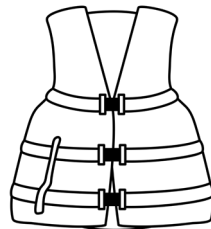

FIGURE 2-3 PFD TYPE 3, WEARABLE

PFD Type IV, Throwable (Figure 2-4) can be thrown to a person in the water, grasped and held by the user until rescued. The most common Type IV PFDs are a buoyant cushion or ring buoy. The throwable Type IV PFD should be immediately available for use and always in serviceable condition. **This PFD is required in addition to the PFDs previously discussed.**

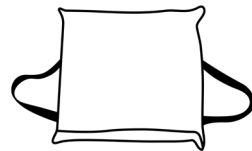

FIGURE 2-4 PFD TYPE 4, THROWABLE

PFD Type V, Wearable (Figure 2-5) must be worn. When inflated, it provides buoyancy equivalent to Type I, II, or III PFDs. When it is deflated, it has little buoyancy. This PFD must be used according to the approval condition on the label and must be worn while underway

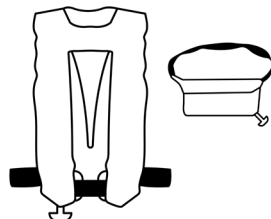

FIGURE 2-5 PFD TYPE 5, WEARABLE

Fire Extinguisher

Class A and Class I boats (power boats 16-26 feet [4.8-7.9m] long) must carry at least one U.S. Coast Guard approved portable fire extinguisher. The extinguisher must have an ABC rating. All hand portable fire extinguishers should be mounted in a readily accessible location away from the engine compartment. Everyone aboard should know where the fire extinguisher is and how to use it. If your fire extinguisher has a charge indicator gauge, cold or hot weather may affect the gauge reading. Consult the instruction manual supplied with the fire extinguisher to determine the accuracy of the gauge.

Sound Signaling Device

Class I boats are required to carry a hand-, mouth-, or power-operated horn or whistle. They are also recommended for Class A boats. It must produce a blast of two-second duration and audible at a distance of at least 1/2 mile (0.8 km). The device should be used to promote safe passing, as a warning to other vessels in fog or confined areas, or as a signal to operators of locks or drawbridges. These are standard whistle signals.

- One Prolonged Blast - Warning signal
- One Short Blast - Pass on my port side
- Two Short Blasts - Pass on my starboard side
- Three Short Blasts - Engines in reverse
- Five or More Blasts - Danger Signal

Navigation Lights

Navigation lights are intended to keep other vessels informed of your presence and course. If you are operating your boat between sunset and sunrise, you are required to display appropriate navigation lights. Do not use docking or exterior courtesy lights while under way.

Visual Distress Signals

U.S. Coast Guard regulations require all recreational boats be equipped with visual distress signal equipment. The regulations apply to boats used on coastal waters, which includes the Great Lakes, territorial seas and those waters directly connected to the Great Lakes and the territorial seas, up to a point where the waters are less than two miles (3.2 km) wide, and to boats owned in the United States when operating on the high seas.

Visual distress signal equipment may be of the pyrotechnic

or non-pyrotechnic type. The equipment must be approved by the U.S. Coast Guard, be in serviceable condition, and be stowed in a readily accessible location. Equipment having a date for serviceable life must be within the specified usage date shown. Careful selection and proper stowage of visual distress equipment is very important, especially if young children are aboard.

No one signaling device is ideal under all conditions or for all purposes. Consider carrying various types of equipment on board. Approved pyrotechnic visual distress signals and associated equipment include red flares, hand-held or aerial; orange smoke, hand-held or floating; and launchers for aerial red meteors or parachute flares. Approved non-pyrotechnic equipment includes orange distress flags and electric distress lights.

Recommended Additional Gear and Equipment

You should consider adding all or some of the following equipment. You may want to add other items depending upon your boating needs.

Basic Equipment

- Anchor and anchor line
- Dock fenders
- First-aid kit
- Oar or paddle
- Flashlight
- VHF radio
- Signal flares
- Sunburn lotion
- Boat hook
- Compass
- Foul weather gear
- Ring life buoy with line
- Tow line
- 2 mooring lines
- Flashlight or portable searchlight
- Extra warm clothing
- Charts of the area

Tools

- Screwdrivers
- Pliers
- Hammer
- Adjustable wrench
- Spark plug wrench
- Jackknife
- Electrical tape
- Lubricating oil
- Duct tape

Spare Parts

- Spare light bulbs
- Spare propeller
- Spark plugs
- Propeller parts
- Fuses
- Flashlight batteries

SAFE BOATING PRACTICES

YOU are responsible for your own safety, the safety of your passengers, and the safety of fellow boaters.

Drugs and Alcohol

Alcohol consumption and boating do not mix! Operating under the influence endangers the lives of your passengers and other boaters. Federal laws prohibit operating a boat under the influence of alcohol or drugs.

Do not use drugs or drink alcohol while operating your boat. Like driving a car, driving a boat requires sober, attentive care. Operating a boat while intoxicated or under the influence of drugs is not only dangerous, it is also a Federal offense carrying a significant penalty. These laws are vigorously enforced. The use of drugs and alcohol, singly or in combination, decreases reaction time, impedes judgment, impairs vision, and inhibits your ability to safely operate a boat.

Safe Operation

Safe operation means that you do not misuse your boat nor do you allow your passengers to do so. Safe operation means using good judgment at all times. It includes, without limitation, these actions:

- Load your boat within the limits listed on the capacity plate. Balance loads bow to stern and port to starboard.
- Maintain boat speed at or below the local legal limit. Avoid excessive speed or speeds not appropriate for operating conditions.
- Do not use your boat in weather or sea conditions beyond the skill or experience of the operator or the comfortable capability of the boat or passengers.
- Be sure at least one other passenger is familiar with the operation and safety aspects of the boat in case of an emergency.
- Make sure that passengers and gear do not obstruct the operator's view or ability to move.
- Do not exceed the maximum engine power rating stated on the certification plate attached to your boat.
- Always keep the front gate closed while the boat is in motion to prevent falls overboard and possible injury by rotating propeller.

- Do not remove or modify the bow rail. It is a safety device!
- Do not allow passengers to sit on foredeck or sundeck while the boat is moving. This will prevent falls overboard and possible injury by the rotating propeller.
- Observe the maximum maneuvering speed posted on the helm of all boats. High-speed turns under certain conditions can be dangerous.
- Make sure engine is off and propeller is stopped before using boarding ladder.

Passenger Safety

Before getting underway, show all passengers where emergency and safety equipment is stowed, and explain how to use it. Everyone aboard should wear shoes which resist slipping on wet surfaces and protect toes and feet from accidental injury. While underway, passengers should remain seated inside the deck rails and gates. Don't allow them to ride on the sundeck or in other unsafe positions. Don't allow passengers to drag their feet or hands in the water. Always use handholds and other safety hardware to prevent falls.

Propeller

Do not allow anyone near a propeller, even when the engine is off. Propeller blades can be sharp and can continue to turn even after the engine is shut off.

First Aid

As a boat operator, you should be familiar with basic first aid procedures that may be needed while you are far from help. Fish hook accidents or minor cuts and abrasions may be the most serious mishaps on board a boat, but you should also learn the proper procedures and be ready to deal with the truly serious problems like mouth-to-mouth resuscitation, excessive bleeding, hypothermia, and burns. First aid literature and courses are available through most Red Cross chapters.

Operation by Minors

Minors should always be supervised by an adult whenever operating a boat. Many states have laws regarding the minimum age and licensing requirements of minors. Be sure to contact the state boating authorities for information.

Rules of the Road

As a responsible boater, you will comply with the "Rules of the

Road," the marine traffic laws enforced by the U.S. Coast Guard. Navigating a boat is much the same as driving an automobile. Operating either one responsibly means complying with a set of rules intended to prevent accidents. Just as you assume other car drivers know what they are doing, other boaters assume you know what you are doing. Chapter 8 has more information about navigational rules and the Rules of the Road.

Voluntary Inspections

State boating officials in many states or the U.S. Coast Guard Auxiliaries offer courtesy inspections to check out your boat. They will check your boat for compliance with safety standards and required safety equipment. You may voluntarily consent to one of these inspections, and you are allowed time to make corrections without prosecution. Check with the appropriate state agency or the Coast Guard Auxiliary for details.

Safe Boating Courses

Your local U.S. Coast Guard Auxiliary and the U.S. Power Squadrons offer comprehensive safe boating classes several times a year. You may contact the Boat/U.S. Foundation at 1-800-336-BOAT (2628) or, in Virginia, 1-800-245-BOAT (2628) for a course schedule in your area. Also contact your local U.S. Coast Guard Auxiliary or Power Squadron Flotilla for the time and place of their next scheduled class.

CARBON MONOXIDE

Burning a material containing carbon produces carbon monoxide (CO), an odorless and colorless gas. You cannot see or smell CO. Because it weighs the same as air, it will distribute throughout an enclosed space without your knowledge. Any device used to burn carbon based materials on your boat or those around you can be a source of CO. Common sources of carbon monoxide include internal combustion engines and open flame devices such as charcoal grills.

The lungs absorb carbon monoxide that then reacts with the blood to reduce the blood's ability to carry oxygen. The reduced oxygen supply to body tissues results in death of the tissue. Prolonged exposure can cause death.

In high concentrations, CO can be fatal within minutes. The effects of CO in lower concentrations are cumulative and can be just as lethal over long periods of time. Symptoms of CO poisoning include: itchy and watering eyes, flushed appearance,

throbbing temples, inability to think coherently, ringing in the ears, tightness across the chest, headaches, drowsiness, nausea, dizziness, fatigue, vomiting, collapse, and convulsions.

If you observe any of these symptoms, begin treatment immediately. Prompt action can make the difference between life and death. Evacuate the area and move the victim to fresh air. Administer oxygen if available and get medical help. Open all canvas to ventilate the area. Investigate the source of CO and take immediate corrective action; be especially aware of sources adjacent to the boat.



Carbon monoxide can be harmful or fatal if inhaled. Keep exhaust outlets clear of blockage. Provide adequate ventilation.

Carbon Monoxide Accumulation

Following are common situations in which carbon monoxide (CO) can accumulate within enclosed areas of your boat while docked, anchored, or underway. Become familiar with these examples and their precautions and be alert to other situations to prevent CO poisoning.



Generator or hull exhaust from other vessels, while either docked or anchored, can accumulate within enclosed areas of your boat. Be alert for generator exhaust from other vessels alongside (Figure 2-6).

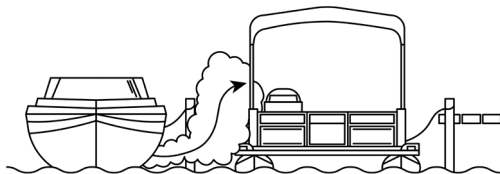

FIGURE 2-6 VESSEL ALONGSIDE

⚠ DANGER

Under certain conditions, tailwind, boat speed, or high bow angle can draw carbon monoxide into enclosed areas (backdrafting). CO can accumulate to dangerous levels without proper airflow. Open front canvas to provide adequate ventilation, redistribute the load, or bring boat out of high bow angle (Figure 2-7).

⚠ DANGER

CO in engine exhaust from your boat can accumulate within enclosed areas when your boat is operating at slow speed or stopped in the water. Installing rear canvas while underway increases the chance of CO accumulation in your boat. Tailwinds can increase accumulation. Provide adequate ventilation or slightly increase speed, if possible (Figure 2-7).

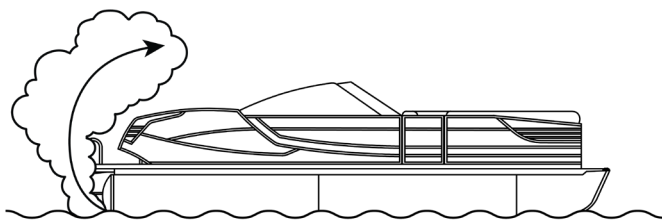

FIGURE 2-7 BACKDRAFTING

⚠ DANGER

With canvas in place, hull exhaust while underway can cause CO to accumulate within enclosed areas. Provide adequate ventilation when the canvas top, side curtains, and/or back curtains are in their closed protective positions (Figure 2-8).

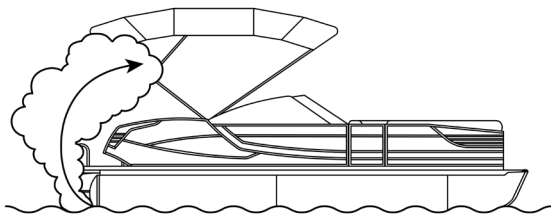

FIGURE 2-8 WHILE UNDERWAY



When hull exhaust outlets are blocked by a pier, dock, seawall, or any other means, CO can accumulate within enclosed areas. Make sure hull exhaust outlets are not blocked (Figure 2-9).

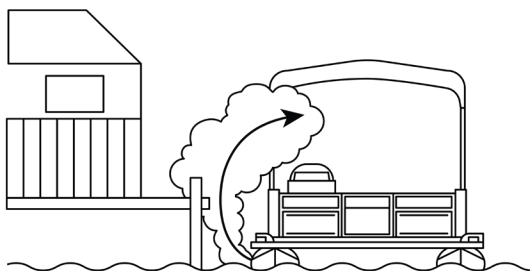

FIGURE 2-9 BLOCKED OUTLETS

Even with the best boat design and construction, CO may still accumulate in enclosed areas under certain conditions. Continuously observe passengers for symptoms of CO poisoning.

CO Detector

We recommend that you have marine grade CO detectors installed in boats with canvas enclosures. Monitors are available from your dealer. Monitors should be professionally installed and calibrated.

Note: A CO detector is not a gas fuel vapor detector. Gas fuel vapor detectors do not monitor the buildup of carbon monoxide in an enclosed area.

! WARNING

The lanyard stop switch must never be removed or modified and must always be kept free from obstructions that could interfere with its operation.

LANYARD STOP SWITCH

Note: This component is supplied by the engine manufacturer. Refer to the engine owner's manual for detailed information about this switch.

This safety device automatically stops the engine when lanyard is attached to the operator and the operator falls or moves away from the control station. The stop switch (Figure 2-10) incorporates a shutoff switch, switch clip, lanyard, and lanyard clip. The lanyard clip is securely attached to the operator's clothing, arm, or leg. Be sure to attach the lanyard to a place where it is free of obstructions and to something that will move with the operator if he or she leaves the helm station.

In order for the engine to run, the lock plate on the end of the lanyard must be attached to the engine stop switch. To reset the switch after engine shutdown, reinstall the switch slip above the interrupter switch and flip the interrupter switch.

Note: The switch on your boat may be different from the typical switch illustrated here. Refer to the engine manual for more information.

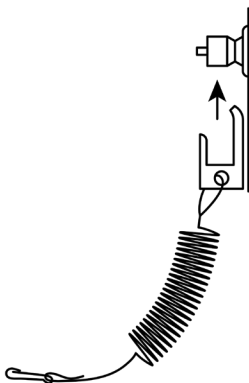

FIGURE 2-10 LANYARD STOP SWITCH

WATER SPORTS



Your boat is not designed for and should not be used for pulling parasails, kites, gliders, or any device which can become airborne. Refer to your tow bar rating before use.

Water skiing, kneeboarding, or riding a towed, inflatable apparatus are some of the more popular water sports. Taking part in any water sport requires increased safety awareness by the participant and the boat operator. If you have never pulled someone behind your boat before, it is a good idea to spend some hours as an observer, working with and learning from an experienced driver. It is also important to be aware of the skill and experience of the person being pulled. Everyone participating in a water sport should observe these guidelines:

1. Allow only capable swimmers to take part in any water sport.
2. Always wear a personal flotation device (PFD) approved by the U.S. Coast Guard. Wearing a properly designed PFD will help a stunned or unconscious person stay afloat.
3. Always participate in water sports in safe areas. Stay away from other boats, beaches, swimmers and heavily traveled waterways.
4. Be considerate of others who share the water with you.
5. Give immediate attention to a person who has fallen. He or she is vulnerable in the water alone and may not be seen by other boaters.
6. Approach a person in the water from the lee side (opposite the direction of the wind). Stop the motor before coming close to the person.
7. Turn off engine and anchor your boat before swimming.
8. Swim only in areas designated as safe for swimming. These are usually marked with a swim area buoy. Do not swim alone or at night.
9. Stay at least 150 feet (45 m) away from areas marked by a diver down float (Figure 2-11).

10. Only attach water sports tow rope to ski tow hardware. Do not attach tow rope to any other part of your boat.

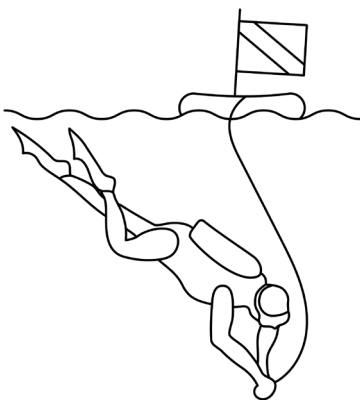

FIGURE 2-11 DIVER DOWN FLOAT

Water Skiing

The popular sport of water skiing has brought a special set of safety precautions to observe in boating. The following guides, in addition to the guides listed above will do much to reduce the hazards while water skiing. For more information about water skiing, please contact the American Water Ski Association, 799 Overlook Drive, Winter Haven, FL 33884 (1-800-533-2972).

1. Water ski only in safe areas, away from other boats and swimmers, out of channels, and in water free of underwater obstructions.
2. Allow no one who cannot swim to water ski.
3. Have a second person aboard to observe the skier and inform the driver about the skier's hand signals (Figure 2-12). The driver must give full attention to operating the boat and the waters ahead.



Skiers must wear a USCG approved personal flotation device. A type III water-ski vest is an approved and practical PFD.



HAND SIGNAL 1



HAND SIGNAL 2



HAND SIGNAL 3



HAND SIGNAL 4



HAND SIGNAL 5



HAND SIGNAL 6



HAND SIGNAL 7

1. THUMB UP: Speed up the boat.
 2. THUMB DOWN: Slow down the boat.
 3. CUT MOTOR/STOP: Immediately stop boat. Slashing motion over neck (also used by driver or observer).
 4. TURN: Turn the boat (also used by driver). Circle motion-arms overhead. Then point in desired direction.
 5. RETURN TO DOCK: Pat on the head.
 6. OK: Speed and boat path OK. Or, signals understood.
 7. I'M OK: Skier OK after falling.
4. Give immediate attention to a fallen skier. Always keep fallen skier on operator's side of the boat when returning to attend the skier. Operator should always have fallen skier in sight. Be careful not to swamp the boat while taking a skier on board.



Switch engine off before taking skiers aboard from in the water. Do not leave engine running in neutral; if the shift is accidentally engaged, propeller can seriously injure skier.

5. Do not water ski between sunset and sunrise. It is illegal in most states.

Systems & Components

This section provides information about your boat's electrical system, instruments, controls, and other equipment.

Note: Some of the equipment described in this chapter may be standard for some models and optional or not available for other models. Check with your Crest Pontoons dealer if you have questions about boat equipment.

ELECTRICAL SYSTEM

DC System

Your boat's electrical system is a 12 volt, direct current (DC) type, similar to the system in an automobile. A battery or batteries supply power to the system. The battery is charged through an engine-driven alternator. A voltmeter at the helm dash shows the charge level of the battery. DC circuit breakers, also at the helm dash, operate 12 volt equipment. Turning the ignition switch off does not cut power to all components.

The battery's negative terminal is connected to the engine grounding stud. This type of negative ground system is the approved system for marine DC electrical systems. Critical circuits are protected by fuses. Inline fuses are in the battery compartment. The fuse block is at the helm console.

The electrical system is wired at the factory to handle factory-installed electrical equipment. Crest recommends that you have your dealer install any additional equipment. An error in wiring the electrical circuits can cause a fire or damage electrical system components. Have your dealer make electrical system repairs and install additional equipment.

If you do add additional equipment, it must be adaptable to the negative ground system. When installing additional equipment, be sure to take the power supply from the circuit breaker panel. If additional circuit protection is required, it must be added at the fuse block at the helm console. Be sure to protect all electrical components from rain, water, or sea spray.

Note: Power feeds for accessory equipment must NOT be taken from the voltmeter terminals. Consult with your dealer for additional DC power needs on your boat.

Battery

The battery was installed on your boat by your dealer. Inspect the battery frequently for cleanliness and tight connections. When you inspect the battery, make sure it is tightly secured. Be sure that the battery compartment is well ventilated. If you need to replace a battery, install the same type as originally supplied with your boat.

If the starting battery is discharged, you can jump start the boat's engine. Before jump starting, determine the cause for the dead battery. In particular, check to see whether any switches or lights were left on. The boat's battery cables do not need to be removed to jump start the engine. Be sure to connect like terminals (for example, positive to positive). The last cable to be connected should be the negative cable of the charged battery.

When you install a battery, battery connections must be made properly. Attach the negative battery cable to the negative (-) terminal on the battery. Then, attach the positive cable to the positive (+) terminal.



POISON! Batteries contain sulfuric acid and can cause severe personal injury if mishandled. Avoid contact with eyes, skin, or clothing. In case of contact, flush with water for at least 15 minutes. If swallowed, drink large quantities of water or milk. Follow with Milk of Magnesia, beaten egg, or vegetable oil. Get medical attention immediately.

Note: You will find the main circuit breaker within 7 inches of the battery on most models. This 25 amp circuit breaker has been installed to conform with U.S. Coast Guard requirements. If you have trouble finding it, ask your dealer to help you.

Charging the Battery

Batteries produce hydrogen and oxygen gasses when they are being charged. These explosive gasses escape through the vent/fill caps and may form an explosive atmosphere around the battery if ventilation is poor. This gas may remain around the battery for several hours after charging. Sparks or flame can ignite the gas and cause an explosion. To avoid explosions, do not use jumper cables and a booster battery to start the engine. Remove the battery and recharge it ashore.

WARNING

During charging, batteries produce gasses which can explode. Explosion can shatter the battery. Battery acid can cause severe personal injury such as blindness. Keep flame, spark, and smoking materials away from battery while charging. Charge battery in a well ventilated area.

Electrical Switches

Electrical switches control the power supply to boat components. Switches may be two-position (off or on) or three-position with a center off position. For three-position switches, switch position determines which components are powered.

The following table summarizes information about boat switches. (Your boat may not have all of the switches listed.)

Switch ID	Components Powered	Switch Type
BILGE	Bilge pump (wired directly to battery)	2-Position on/off or 3-Position on/auto/off
BLOWER	Engine compartment blower	2-Position
DOCKING LTS	Docking lights	2-Position
HORN	Horn	Spring-loaded (toggles off when released)
NAV/ANC	Navigation lights or anchor lights	3-Position
LIGHTS	Interior and exterior lights	2-Position
ACC (number varies by model)	Accessories (varies with boat equipment)	2-Position
MASTER POWER	Activates power to all components except bilge pump (wired directly to battery)	2-Position

Note: Circuit breakers protect electrical devices from damage caused by power surges. If you reset a breaker and it immediately trips again, do not attempt to reset it a second time. Retripping indicates an electrical problem that needs dealer attention.

IMPORTANT: Some boat components, such as the stereo (if provided), are still powered even though the ignition switch is off. To prevent discharging of the battery, turn off power to all components when they are not being used. It is a good idea to turn all switches off if you are leaving your boat for an extended period of time.

INSTRUMENTS

Note: The instruments provided may vary from boat to boat. Instruments are listed in alphabetical order.

The instruments installed on your boat indicate current operating conditions for the engine and related systems. When you take delivery of your boat, ask your dealer about the normal readings of the gauges. This provides you with a reference point to evaluate how well your boat is operating. Keep in mind that the readings on some gauges tend to fluctuate. You should investigate the cause for gauge readings that show a continuous variance or a sudden, substantial variance from normal readings.

Depth Gauge

This gauge provides a digital readout of water depth. Refer to this instrument's manual for more information.

Fuel Gauge

The fuel gauge shows the approximate amount of fuel in the fuel tank. Note that the actual fuel supply may vary slightly from that shown on the gauge. The most accurate reading of the fuel gauge is at idle speed when your boat maintains an approximately level position. While underway, the fuel gauge usually indicates that the tank is fuller than it actually is because the bow tends to be higher than when the boat is at rest. Since gauge readings are approximate, they should be compared to the hours of use versus known fuel consumption per hour.

The most common practice of good fuel management is the one-third (1/3) rule. Use 1/3 of your total fuel to travel to

your destination, 1/3 to return, and keep 1/3 in reserve for emergencies.

Hour Meter

This instrument indicates the accumulated number of engine operating hours.

Oil Pressure Gauge

The oil pressure gauge is a good indicator of most, if not all, serious problems that may occur within your engine. A preset valve in the oil pump controls the maximum oil pressure. Check the engine oil level before every trip and fill if low. If oil level is full and gauge reading is low, contact your dealer or a qualified mechanic to rectify the problem. Do not restart the engine until correcting the problem. See the engine manufacturer's specifications for correct pressure ranges.



Engine Damage! Operation at low oil pressure can seriously damage engine. Stop engine immediately if oil pressure falls below the normal range. (Check with your dealer if you are not sure what the normal range is for your boat's engine).

Speedometer

The speedometer indicates the speed your boat is traveling across the water in miles per hour. Water pressure from a water pickup at the boat's stern is measured and converted into a reading on the boat's speedometer.

Tachometer

The tachometer displays the engine operating speed in increments of 100 revolutions per minute (RPM). The tachometer shows engine speed in RPMs under various engine operating conditions. Consult your dealer if you need more information.

Temperature Gauge

The temperature gauge measures the temperature of the engine cooling system. Check this gauge right after you start

the engine. If the temperature gauge shows that the engine is hot, stop the engine immediately. Refer to your engine owner's manual for instructions and corrective action.

Trim Gauge

The trim gauge indicates the relative position of the drive unit. Read this gauge carefully, as it does not show position of unit in degrees. Proper trim should be indicated by bow attitude and engine RPM. For more information see your engine owner's manual.

Voltmeter

The voltmeter shows battery voltage. If the engine is running at normal speed (1000 RPMs or higher) and the alternator is charging, the reading on the meter ranges between 12.0 to 15.5 volts. If the meter reading is high (between 12.0–13.5 V is normal when fully charged) when the engine is not running and the ignition key or switch is ON, the battery is fully charged. Significantly higher or lower readings indicate a battery problem, alternator malfunction, or heavy drain on the battery. Check the charging system and the battery system for the cause of these readings. An oscillating reading shows a loose voltage regulator connection or loose belts. Low voltage readings after stopping the engine indicate a bad battery, a heavy load on the battery, or failure of the charging system. Refer to your engine owner's manual for proper gauge readings.

CONTROLS

Knowing how to use the controls on your boat is essential for safe and proper operation. The controls described in this section may be optional or may vary slightly from those on your boat.

Throttle and Gearshift

The controls on your boat may vary from model to model and depend on what kind of engine your boat has. The control described here is typical of the operation of most throttle/gearshift controls. Check the engine or control manual or see your dealer for more detailed information.

A single-lever control integrates the throttle and gearshift into a single hand lever. It allows the operator to control both the engine operating speed and the forward and aft movement of the boat. This type of design ensures safe control of the engine with one hand.

The lever automatically locks in the neutral position. This is a safety precaution intended to prevent starting the engine with the drive engaged. You must press the neutral lock release button in order to move the lever from the neutral position. The lever functions as shifter during the first 15° of motion forward or back. Beyond 15°, it functions as a throttle. Pushing the lever toward the full throttle position increases engine speed.

Here are a few helpful operating tips:

- When shifting between forward and reverse, always pause in neutral for a few seconds before reversing propeller rotation to prevent damage to the engine and drive.
- When maneuvering at low speeds, you can reverse the throttle (move throttle forward or aft) to control or brake boat travel.
- Gradually increase speed when moving in reverse. High speed acceleration in reverse can create a wake that could flood the boat.

Steering

Various steering systems are used on Crest pontoons. Some models have a tilt steering wheel and an enclosed mechanical push-pull cable system connected to the motor. A hydraulic steering system is available as an option as well as Electric Power Steering (EPS).

Getting the “feel” of your boat’s steering system is important. Steering does vary from boat to boat depending on the type of engine, water and wind conditions, and the load. Turn the wheel from full left to full right. Check that the drive unit is turning correctly, freely, and smoothly. The cable output end of the steering system should be clear of fuel lines, control cables, electrical wiring, and outboard gear when an engine is moved through its full operating range.

All steering systems require periodic maintenance to be trouble-free and safe. Regular checks are essential. Check the cables regularly and tighten them as needed. Be sure to read the manufacturer supplied operator’s manual before heading out on the water.

Hydraulic Steering/EPS System

A hydraulic steering system is available as an option for some models. Hydraulic steering makes it easier to control the boat

because the wheel is easier to turn. Operators should be careful that they do not “oversteer,” that is, turn the wheel too far so that a turn is tighter than intended. See your dealer or the steering system manufacturer information regarding routine maintenance for these systems.

Power Trim

A power trim system is available on all models. The power trim system controls the angle of the outboard motor. The power trim switch also allows the operator to adjust the motor at cruising speed to achieve an ideal planing angle. Moving the outboard closer to the transom is called trimming “in” or “down.” Moving the outboard further away from the transom is called trimming “out” or “up.” Refer to the engine and control manuals for specific information about trimming.

To trim the bow of the boat up, press the trim switch in the direction marked UP. Moving the bow up may increase top speed, but can cause the boat to porpoise if trimmed up too far. Excessive trim up can cause propeller cavitation (propeller pushes air, not water).

To trim the bow of the boat down, press the trim switch in the direction marked DOWN. Running with the bow down helps the boat accelerate and get on plane faster, especially with a heavy load. It can also help improve the ride in rough water, but it reduces boat speed in most cases. Excessive trim down can make the boat difficult to steer.

TROLLING MOTOR

An electric trolling motor is available as optional equipment on some models. This motor, which mounts on the bow of your boat, plugs into a receptacle on the bow of the boat. It is powered by a separate deep cycle marine battery supplied by your dealer. Check with your dealer and refer to the trolling motor owner’s manual for operation and maintenance instructions.

LIVEWELL

An aerated livewell is standard on some models. The livewell provides an environment where your catch can be kept alive and healthy. Figure 3-1 shows a typical livewell. The livewell on your boat may be slightly different than the one shown.

You should monitor water and air temperatures to determine when and how often you should aerate the livewell. You can turn the livewell pump on and off manually. (The pump is wired to an accessory switch.) The pump runs continuously when the switch is on.

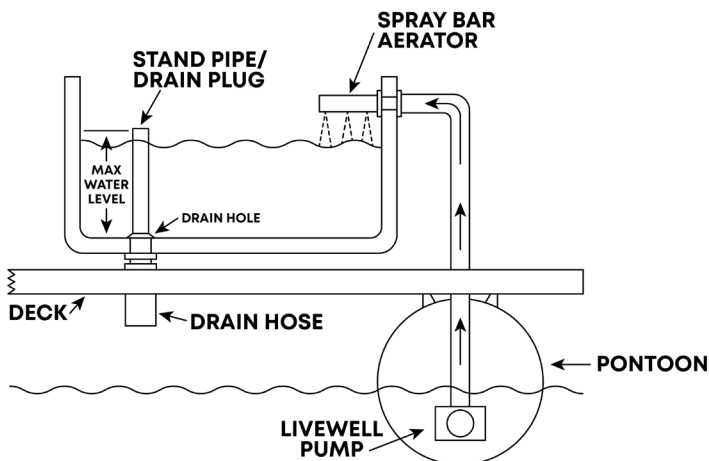

NOTE: LIVEWELL LOCATION VARIES BY MODEL

FIGURE 3-1 TYPICAL LIVEWELL

The pump draws raw water in through a fitting below the waterline and pumps it into the livewell. The pump fills the livewell with raw water. Water sprays into the livewell through the aerator spray bar. The spray bar has an adjustable valve which you can use to control the volume of water flowing into the livewell. As the incoming water hits the surface of the water in the livewell, the water's oxygen content increases which helps keep fish alive. As water continues to spray into the well, excess water flows out through the standpipe and drains overboard. Drain locations vary by model.

The livewell pump works best when the boat is at rest or operating at trolling speeds. At faster speeds, the pump does not operate properly because it cannot draw in water. If water

does not come out of the spray bar, stop the pump and correct the problem (for example, blown fuse, broken wires, closed flow control valve, plugged inlet). If the problem persists, check with your dealer.

If the overflow or drain becomes plugged, try back-flushing it with a garden hose set at low velocity. Some models have a screen at the pump intake. Remove the screen before back-flushing. Often the obstruction will blow back into the livewell where it can be easily removed. Be careful that you do not use too much pressure. You can blow the hoses off the fittings.

Do not use the livewells to hold bait. Bait can be lost, or plug the drains.

CANVAS

Your boat may be equipped with protective coverings such as a bimini top, mooring cover or a privacy unit. To prevent mold and mildew buildup, it is important to let the canvas material completely air dry before storing. Ask your dealer to show you how to set up and store these coverings.

AUDIO SYSTEMS

Crest Pontoons utilizes various manufacturers on different models. Please consult your boat's audio system manual for specific operational needs, features and detailed instruction.

Trailer

A correctly selected trailer supports your boat properly, makes towing safer, and makes loading and unloading easier. Proper trailer selection and setup are very important. Improper trailering is one of the major causes of damage to the pontoon. Your pontoon must be well supported to prevent any damage during trailering. The pontoon's weight should be supported the entire length of the pontoon with a bunk trailer or the entire deck length with a mechanical folding trailer. Your dealer will help you choose the right trailer and explain how to use it. To avoid corrosion damage to the pontoons do not use trailer(s) with carpeted bunks in salt or brackish water. Crest Pontoons will not be held liable for any damages caused by improper trailer setup or operation.

TRAILER

Gross Vehicle Weight Rating

Your trailer should be able to accommodate the weight of the boat, engine, full fuel tank, and any other equipment normally carried. Check the certification label on the frame of the trailer for the Gross Vehicle Weight Rating (GVWR). The total weight of the boat, engine, fuel, gear, and trailer should not exceed the GVWR. To determine the total weight of your boat, take it fully loaded to a scale and have it weighed.

Remember that the published weight is the dry weight of your boat. Dry weight does not include the weights of outboard motors, batteries, gasoline, any optional items, gear, or trailers. The weight of these items must be added to the dry weight to determine the proper trailer GVWR needed. If your boat is equipped with a larger than standard engine, you must allow for the engine's added weight.



The total weight of the trailer, boat, and gear must not exceed the GVWR of the trailer. Overloading can cause accidents.

Weight Distribution

If your towing vehicle is equipped with a weight distribution hitch, it must be capable of handling the GVWR. The weight on the trailer should be evenly distributed and can be checked by determining the tongue weight.

Tongue weight is a percentage of the total weight of the loaded trailer on its tongue. Ideal tongue weight is not less than five percent (5%) and not more than ten percent (10%) of the GVWR. For example, if the weight of the loaded trailer is 3000 pounds (1361 kg), the weight on the tongue should be more than 150 pounds (68 kg), but less than 300 pounds (136 kg). Excessive tongue weight causes the front end of the towing vehicle to sway. Insufficient tongue weight causes the trailer to sway or fishtail.

To avoid personal injury and property damage, be sure to balance the load when trailering. If too much weight rests on the hitch, the front end of the vehicle will sway or oversteer. Insufficient weight on the hitch causes the trailer to fishtail. In either case, the vehicle will be hard to handle and could become uncontrollable at high speeds.

State regulations usually require that trailers above a specified weight rating be equipped with brakes. Requirements vary; check with your dealer for additional information.

HITCH



The total weight of your loaded trailer must not exceed the capacity marker on the hitch of your tow vehicle. Overloading can cause hitch failure, leading to injury-causing accidents.

Hitches are divided into classes that specify the gross trailer weight (GTW) and maximum tongue weight for each class. Always use a hitch with the same class number as the trailer. Most boat trailers connect to a ball hitch that is bolted or welded to the towing vehicle. Special heavy-duty equalizing hitches are necessary for trailer tongue weights of 350 pounds (158 kg) or greater.

The trailer hitch coupler must match the size of the hitch ball. The correct ball diameter is marked on the trailer coupler.

SAFETY CHAINS

Safety chains on the trailer provide added insurance that it will not become completely detached from the towing vehicle while underway. Crisscross the chains under the trailer tongue to prevent the tongue from dropping to the road if the trailer separates from the hitch ball (Figure 4-1). Safety chain should be of the "Proof Coil" type and must have a minimum breaking strength equal to the upper limit of the GVWR. Some states require chains to be locked so hooks can't shake, bounce, or vibrate off the bracket.

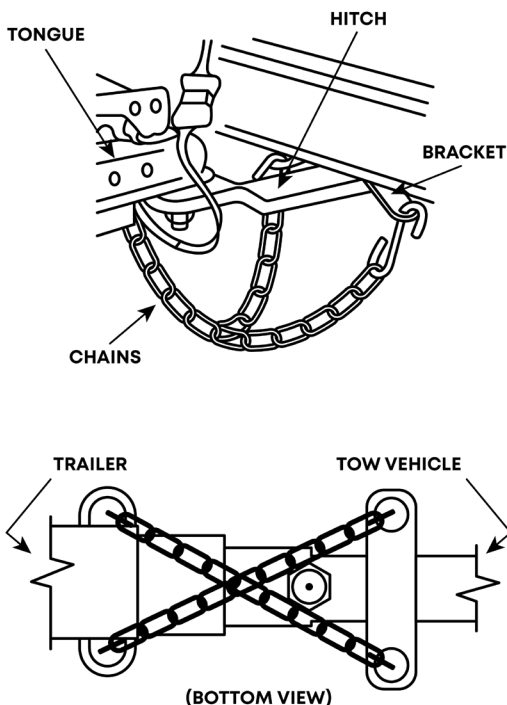

FIGURE 4-1 SAFETY CHAINS

TRAILERING GUIDELINES

1. Be sure that the bunks support a large amount of pontoon surfaces and they distribute weight evenly on the trailer.
2. Make sure your boat is properly tied down and a safety chain is used.
3. Do not trailer with the boat's bimini top or mooring cover on. Make sure cover is properly stored in the optional trailer kit available from your dealer and sundeck is properly secured. They can be severely damaged while trailering.
4. Be sure your trailer is equipped with functional tail lights and turn signals as required by state and federal laws.
5. Check with your state Department of Motor Vehicles for registration and licensing regulations in your state. Some states require that boat trailers be registered and licensed.
6. Be aware that a turn for the trailer is wider than a turn for the tow vehicle (Figure 4-2). When making a turn, be careful that your trailer does not strike another vehicle or object.

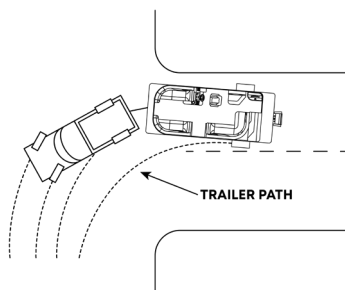

FIGURE 4-2 TURNING WITH TRAILER

7. Inspect your trailer regularly to make sure the side supports are in good working order. Check bolts which secure rollers and supports for tightness. Check wheel bearings frequently for sufficient grease.
8. Check local and state laws for any additional requirements for trailers

BACKING A TRAILER

If you do not have experience in backing up with a trailer, practice backing with a trailer before you get into a confined launch site. Get accustomed to using your trailer in an open area. Take someone with you who knows how to back a trailer.

Backing a trailer works the opposite of backing a car. If the trailer needs to travel to the right, turn the steering wheel to the left and vice versa (Figure 4-3). Do not turn the wheel too far or oversteer. Turn the wheel gradually until you get the feel of safe backing.

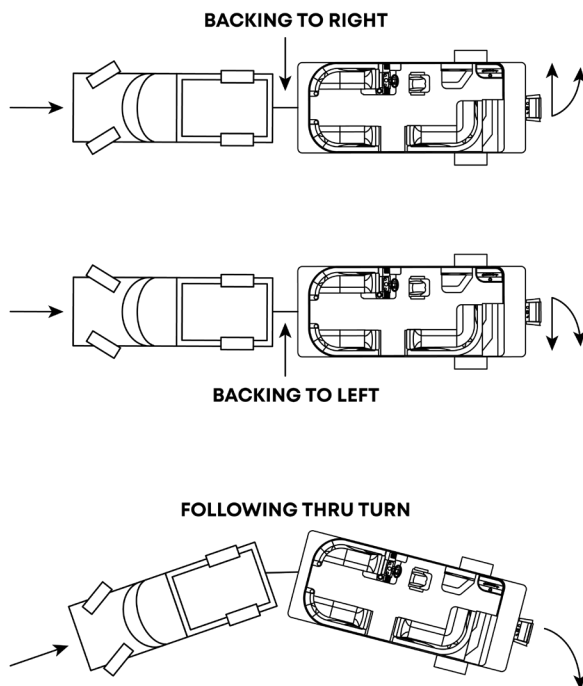

FIGURE 4-3 BACKING A TRAILER

LAUNCHING GUIDELINES

Before launching, stay to one side and watch a couple of launchings to notice any problems on the ramp and the effects of the wind and the current on launching. It's a common courtesy to prepare the boat for launching away from the ramp.

Note: If you have a bunk trailer, the boat's transom must be deeper than several inches in the water before launching.

Here are some tips to remember when putting your boat in the water:

1. Before backing down the launch ramp
 - Remove all stern tie-downs.
 - Properly secure all loose gear.
 - Inventory your safety equipment.
 - Load all personal gear.
 - Lock winch and trailer unit.
 - Disconnect trailer wiring from towing vehicle to prevent short circuits caused by submersion.
2. Have an individual at the launch ramp give you directions. Back slowly down the ramp. If the trailer needs to be maneuvered to the right, turn the towing vehicle's steering wheel to the left. If trailer movement to the left is required, turn the steering wheel to the right. Always remember to launch your boat at a right angle to the shoreline.
3. If launching from a trailer, tilt the outboard motor up to the high tilt trailer position to avoid damage during the launch.
4. When the boat's transom is in several inches of water, stop towing vehicle. If you have a manual transmission, leave it in gear. If you have an automatic transmission, shift to PARK.
5. Turn off the engine and set the parking brake.
6. Place blocks behind the vehicle's rear wheels. (If blocks are connected with a rope to the trailer tongue, you will not need to remove them before pulling the trailer out.)
7. Do not detach the winch cable from the bow eye until a mooring line has been secured to one of the boat's cleats. Attach one line to bow and one line to the stern to help control the boat. See the Mooring information in Chapter 5 for suggested securing procedures.

8. Launch the boat; move it down and OFF the trailer into the water.
9. Secure boat to dock or have someone hold mooring lines.
10. Lower outboard all the way into the water.
11. Pull your towing vehicle away from the launch ramp.
12. Park only in designated areas. When parking, be sure your towing vehicle and trailer do not block other boaters from approaching the launch ramp or hinder their ability to maneuver a boat and trailer when launching.

LOADING YOUR BOAT ON THE TRAILER

Follow these guidelines for loading the boat back onto the trailer:

1. Back the trailer into the water.
2. When the trailer is in several inches of water:
 - STOP the towing vehicle.
 - Leave manual transmission in gear or place automatic transmission in park.
 - Turn off the engine.
 - Set the parking brake.
 - Place blocks behind the vehicle's rear wheels.

Note: If you have a bunk trailer, the trailer may need to be more than several inches in the water before loading. If you find it difficult to load your boat, you probably have the trailer too deep in the water.

3. Tilt the boat's engine up to the high tilt position to avoid damage while loading
4. Pull or drive the boat up onto the trailer and secure the safety chain.
5. After securing the boat to the trailer start engine on towing vehicle and pull trailer out of water to boat securing area
6. Use tie-downs to secure the boat on the trailer. Always use bow and stern tie downs and bow and stern trailer safety eyes (welded to each pontoon) to prevent the boat from shifting.
7. Wipe down pontoons to prevent water spots and keep the boat clean.
8. Make sure everything in the boat is secure or tied down.

Do not put other gear in the boat while trailering. Place anything loose in the towing vehicle.

9. Reconnect trailer lights. Check that the lights are working.
10. Remove milfoil, zebra mussels, or other aquatic growth from pontoons to protect and maintain our boating waters.

Underway

BOATER'S CHECKLIST

Go through the following checklist before starting on your cruise:

- Will the weather be favorable? Did you get a current weather report?
- Is there a suitable licensed operator? Is the operator impaired from drug or alcohol use?
- Are all passengers off the upper deck (if provided)?
- Are all passengers inside deck rails? Are all gates properly secured?
- Are pontoons and propellers free of damage, excessive dirt, and marine growth?
- Are electrical systems and navigation lights working?
- Is the battery fully charged? Are connections clean and tight?
- Is your boat overloaded or underpowered (compared with capacity plate)?
- Is all required safety equipment on board? Does it work? Is there one PFD for each passenger? Is safety equipment easily accessible?
- Is the lanyard safety switch working?
- Is other needed equipment on board such as mooring lines, anchor and line, tool kit, first aid kit, etc.?
- Do you have enough fuel for your trip? Fuel tanks should be filled to slightly less than capacity. Allow space for fuel expansion.
- Have you checked fuel system for odors, leaks, and deterioration?
- Have you checked the motor for leaks or signs of deterioration? Are fluid levels OK (engine oil, battery water, power steering fluid, etc.)?
- Is the engine free of obstructions? Are there any persons near the propeller?
- Does the steering system work smoothly? Are all components tight?
- Do you have navigation charts and equipment on board? Are you familiar with area where you will be boating?
- Do passengers and crew know what to do in an emergency? Do they know how to use safety equipment?
- Do you have an emergency supply of food and water?
- Do you have all required documents on board?
- Have you told a responsible party ashore where you are going and when you expect to return?

This chapter provides basic information for a typical boating excursion. All boaters are responsible for their own safety and the safety of others. Even though you may be an experienced operator, you can still benefit from reviewing the boating principles discussed in this chapter. Before you get underway, make sure you are familiar with local and governmental boating regulations and restrictions.

Note: This chapter may refer to equipment and components that are standard on some models and optional or unavailable on other models.

FUELING

If possible, fill the boat's fuel tank before loading passengers and gear. If passengers are on board, have them leave the boat until fueling is complete.

Fuels containing any form of alcohol derivatives are not recommended for use on marine components and engines. Alcohol destroys marine fuel system hoses and components. Weakened hoses can lead to hazardous leaks, fire, or explosion. If only gasoline containing alcohol is available, or the presence of alcohol is unknown, you must inspect the system more frequently.

Inspect fuel system for leakage, weakening, hardening, swelling, or corrosion of components including fuel tanks, fuel lines, fittings, fuel filters, and carburetors. If any component shows signs of leakage or deterioration, it must be replaced before starting the engine.

 **DANGER**

Fuel vapors are explosive. Fuel leaking from any part of the fuel system can lead to fire and explosion that can cause serious bodily injury or death.

IMPORTANT: If 1/2 pint of gasoline explodes, it has the same power as 5 sticks of dynamite. Before you start filling the fuel tank, securely moor boat to dock. Stop the engine. Extinguish all smoking materials. Turn off all electrical equipment, engines, lights, bilge blower, etc. Do not use anything that can produce a spark or flame. Always fill the tank in an area having adequate lighting. You may not see gasoline spills under poor lighting or in darkness. Make sure a fire extinguisher is readily available.

Follow these procedures to fill the primary tank:

1. Remove fuel fill cap from tank fitting and insert fuel supply nozzle.
2. After pumping approximately 5-10 gallons (19-38 liters) of fuel into tank, inspect engine and fuel tank area for signs of fuel leakage. If fuel cannot be pumped into the tank at a reasonable rate, check for a plugged fuel vent or a kink in the line. Continue fueling if you do not find any leaks or other problems.
3. Stop filling the tank before fuel overflows. Allow space at top of tank for thermal expansion. Fuel pumped from underground tanks is cooler than outside air. Gasoline expands as it warms up and can easily overflow.

IMPORTANT: Gas will shoot out of vent if the tank is overfilled or vent is blocked. Spilled fuel damages the environment. Fuel can damage vinyl and floor coverings.

4. When you have finished fueling, replace the fuel cap. If necessary, wash off any fuel spilled around the fuel fill area. Properly dispose of rags used to wipe off fuel spillage.

LOADING PASSENGERS AND GEAR



Overloading and improper distribution of weight are significant causes of accidents. Capacity plates, located near the helm, show maximum loads under normal conditions. Keep weight below maximum limits for safety in turbulent waters. Overloading is a violation of U.S. Coast Guard regulations. Boats under 27 feet (8.2 m) long are subject to U.S. Coast Guard safe loading and labeling requirements.

Overloading and improper distribution of weight are significant causes of accidents. Capacity plates, located near the helm, show maximum loads under normal conditions. Keep weight below maximum limits for safety in turbulent waters. Overloading is a violation of U.S. Coast Guard regulations. Boats under 27 feet (8.2 m) long are subject to U.S. Coast Guard safe loading and labeling requirement

The U.S. Coast Guard requires that a plate stating the maximum load capacity be affixed to boats up to 27 feet (8.2 m) long. This plate shows the load in pounds (persons and gear) the boat can carry safely under normal conditions. The U.S. Coast Guard establishes these load capacity ratings.

You are responsible for using common sense and sound judgment when loading your boat. Arrange passengers and load in the boat so the weight is evenly distributed. Weight distribution affects your boat's performance. Keep the load low. Have someone on the dock pass your gear aboard. Secure all gear firmly so that it will not move or interfere with boat operation. Be sure all required safety gear is aboard and easily accessible.

Note: It is not uncommon for individual pontoons to settle in the water at different depths. This can be caused by varying weight distribution from various floor plans, gear placement, and differing fuel loads. It is not unusual for one pontoon (or corner) to float higher or lower than the other side. This is merely a matter of how the load balances on the boat, not a defect in the boat.

BOARDING



Wet surfaces can be slippery. Passengers should wear adequate deck shoes while boarding and underway to avoid accidental slip- ping and injury.

Passengers should board the boat one at a time. Always step onto the boat, never jump. Passengers should enter and exit the boat through an open walkway. The boat should only be boarded and exited when it is in a stationary position. Check that all passengers are seated in a proper seat. Do not allow passengers to ride outside the deck rails, on the sundeck, or the foredeck. Falls from moving boats are a major cause of marine accidents.

REBOARDING

For unassisted reboarding, make sure that all passengers understand the process to minimize the chance of injury. Never climb on the pontoons to enter or exit the boat. Always use a boarding ladder when entering/exiting the water. An unassisted reboarding ladder is standard on all Crest pontoons and is mounted on the stern of the starboard side of the boat on single engine models and in the center of the stern for twin engine models. The ladder is placed as far as practical away from the propellers to avoid the chance of injury. This ladder is to be used only while the engine is turned off. The reboarding ladder is accessible to, and deployable from the person in the water.



Rotating propeller may cause serious injury or death. Do not approach or use ladder when engine is running.

Note that exhaust outlets are in the stern of the boat, which are in the proximity of the reboarding ladder. Consideration to carbon monoxide poisoning should be attended to when using the reboarding ladder, even when the engine is off.

LAYOUTS AND SEATING

Propeller ventilation can be a severe problem if too much weight is too far forward. This can be a problem on models in which the seating area extends all the way to the front of the boat. Fish boats may also have the added weight of a trolling motor and battery at the front. For proper performance in such cases, the operator must make sure the load is balanced by shifting the weight of passengers and gear toward the back of the boat. Also, the number of passengers must not be greater than the number of seats.



Passengers occupying swivel or high platform seats may be thrown overboard while accelerating or during sharp turns when running at speeds greater than trolling speed. Injury or drowning is possible. Be sure all passengers are seated properly. Follow instructions stated in safety labels on seat posts.

Be sure all passengers are seated properly in a designated seating position (Figure 5-1) and positioned to balance the load in the boat. Swivel and high platform seats may turn suddenly while underway. These seats are designed for use while fishing or boat is moving at trolling speed. Whenever the boat is running at speeds greater than 5 mph (8 km/h), passengers should remain seated in designated seats. Seats designed for use at cruising speeds are stationary, have a locking handle, or have a lever lock. For seats with a locking handle, turn the handle clockwise until it is hand tight to keep the seat from swiveling. Turning the handle too tight will damage seat. For seats with a lever lock, slide the lever into the slot. See the labels on the seat posts for additional information.

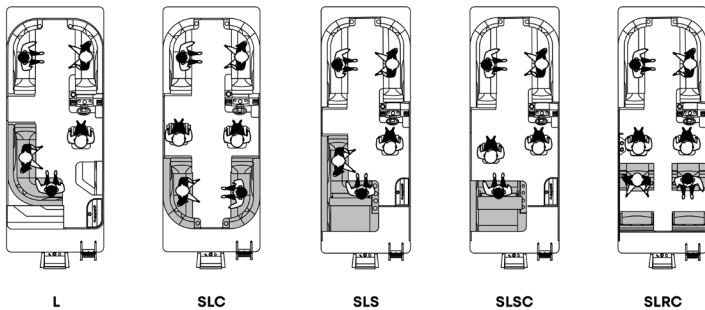

FIGURE 5-1 SEATING
EVEN WEIGHT DISTRIBUTION FOR FLOORPLANS

STARTING THE ENGINE

The following information is merely a guide and not intended to explain in detail all starting procedures and instructions.

Refer to the engine owner's manual for detailed pre-start and starting instructions specific to your boat's engine.

Note: Some models may have a keyless ignition. Starting procedures vary slightly from those provided here. The keyless ignition system manual has starting instructions for boats so equipped.

Outboards

1. Secure the boat to the dock or mooring slip before attempting to start the engine.
2. Lower outboard to the run position. Make sure all cooling water intake holes are submerged.
3. Check fuel supply to ensure you have enough fuel for the expected travel plan.
4. Squeeze fuel line primer bulb several times until it feels firm (portable fuel tanks only).
5. Attach stop switch lanyard to operator. See engine owner's manual for specific instructions.
6. Make sure throttle is in neutral position.
7. If you are starting a cold engine, move fast idle lever to mid-position.

8. Turn the key to START position. Do not operate starter continuously for more than 10 seconds without pausing. Allow starter to cool between start attempts. See engine owner's manual for details.

Note: Engine will not turn over if throttle is not in the neutral position. engine does not turn over, throttle may not be in neutral. Move throttle lever up and down slightly and try again.

9. If the engine is equipped with a carburetor, run engine approximately one to two minutes at fast idle speed (1200 to 1500 RPM) to warm up engine. Keep boat secure at dock until engine is warmed up. Return fast idle lever to down position after warm up.



Gasoline vapors are highly explosive. To prevent a possible explosion and fire, check for fumes or accumulation of fuel before each engine start.

LEAVING THE DOCK

After the engine has warmed up, you are ready to leave the dock. Before you cast off, make sure the front gate is closed and passengers are properly seated. No passengers should be sitting on the foredeck in front of the front gate. Check all gauges for proper readings. If oil pressure reading is abnormally low or temperature reading abnormally high, **stop engine immediately**. Check the operation of the steering by turning the steering wheel to full port and to full starboard while observing outdrive movement. With boat still securely moored to the dock and engine idling, move the throttle forward, then aft, then back to neutral to check for proper shifting. Check wind, tide, and current or other forces that will affect the way you maneuver your boat away from the dock. Release mooring lines and stow fenders.

When you have completed these pre-departure checks, shift your boat engine into forward or reverse depending on whether you want to move the bow or the stern away from the dock first. Move the throttle lever to neutral. Then push forward quickly and firmly to shift into forward gear or pull back to shift into reverse. Your engine should be running at a slow speed as you move away from the dock. If you move the bow out first, watch that the stern does not swing into the dock or piling.

⚠ WARNING

Passengers are to remain seated while casting off and underway. Sudden or unexpected movements may cause passengers to fall. Make sure passengers seated ahead of the helm console do not obstruct driver's vision.

STEERING

Boat steering is not self-centering. Steering is affected by engine and propeller torque, trim tab setting, wave and current action, and the speed of the pontoons through the water. Constant attention to steering is required for safe operation.

Watch the stern when you turn! Steering a boat is like driving a car with rear-wheel drive on slippery pavement (Figure 5-2). When you turn the steering wheel, the stern responds first by swinging in the opposite direction of the bow. When you are leaving the dock or trying to avoid an object in the water, this swing can be critical.

Always give yourself plenty of room to make a turn. You should also slow the speed of your boat while turning. Never make sharp, fast turns because you can easily endanger your passengers or lose control of your boat.

When making tight turns, trim engine in for better handling. Since both the thrust and steering are at the stern of the boat, the stern pushes away from the direction of the turn. The bow follows a smaller turning circle than the stern (Figure 5-3).

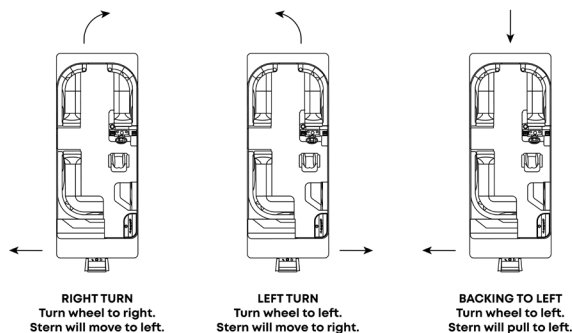

FIGURE 5-2 STEERING

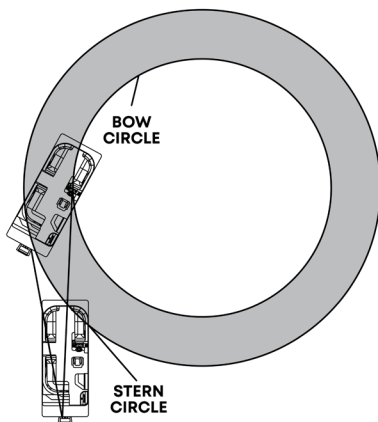

FIGURE 5-3 TURNING

BOAT SPEED

The maximum speed at which you can make sudden turns without losing control of your boat is the maneuvering speed of your boat. Maneuvering speed varies depending on wind, waves, and other factors. Some boats display a warning advising that maneuverability above a given speed is limited. This speed is based on tests in calm water. There are minimum safe speeds for certain conditions as well, maintaining headway in a cross wind, for example. Some careful experimentation will serve you well later. When you encounter a potentially hazardous situation, adjust speed accordingly.

Pace your speed so that you have enough time to respond to an emergency. Never drive your boat directly behind a water skier in case the water skier falls. For example, at 25 miles per hour (40 km/h), your boat is traveling more than 35 feet per second (10.7 m/s). If a skier falls 200 feet (61 m) ahead, your boat will overtake the fallen skier in less than 6 seconds.



Acceleration at full throttle is not recommended during the motor break-in period. Refer to the owner's manual for the correct way to break in your boat's motor.

Accelerating

When you accelerate, your boat's engine increases the trim angle which causes the boat to ride bow high. You may not be able to bring your pontoon boat on plane as you would a vee-bottom boat. Engine size, the weight of the load, and how the load is placed are factors that can affect performance. If you can get your boat on plane, do so as quickly as possible. It should only take a few seconds at full throttle for your boat to level out. Then, accelerate until you reach a comfortable plane and throttle down to cruising speed. This also provides for better fuel efficiency.

Trimming

The following summarizes general principles for trimming your boat. For a more detailed discussion of trimming, refer to your engine owner's manual about the trim controls installed on your boat.

Note: Trimming, as described in this section, may or may not affect your boat's performance or running attitude significantly. The ability to trim depends on the size of your boat, its engine, and the weight and placement of the boat's load. On some pontoon boats, where you place passengers and gear may have the greatest effect on the boat's running attitude or trim. If you have questions, your dealer can explain the extent to which trimming can affect performance.

The outboard can be trimmed to adjust to the ideal boat angle for given load and water conditions. Depending on the motor provided with your boat, it will have power trim controls or a manual tilt system. With either system, the outboard should be trimmed so that it is perpendicular to the water when the boat is running at full speed (Figure 5-4).

On two-pontoon boats, trimming the motor does not significantly affect boat attitude, but it does improve engine efficiency. On the other hand, a tritoon boat is likely to ride higher in the water. It accelerates more rapidly and is more responsive in turns. Trimming is more likely to affect boat attitude, but the effect will be less than trimming a boat with a planing hull.

On boats equipped with power trim controls, trim can be adjusted while running. Trimming out or up lifts the bow upwards and generally increases top speed. Excessive trimming up can cause the boat to porpoise (Figure 5-4). Trimming in or down pushes the bow downward and can help improve the ride

in choppy water. However, excessive trimming down can cause the front of the pontoon to plow through the water and can slow the boat down (Figure 5-4).

You can quickly correct minor deficiencies in your boat's ride by shifting passengers or gear forward or aft. Shifting weight has the same effect as changing the angle on the drive unit. By taking a little extra time to carefully place such items as coolers, water jugs, and the anchor, you can create a more desirable trim.

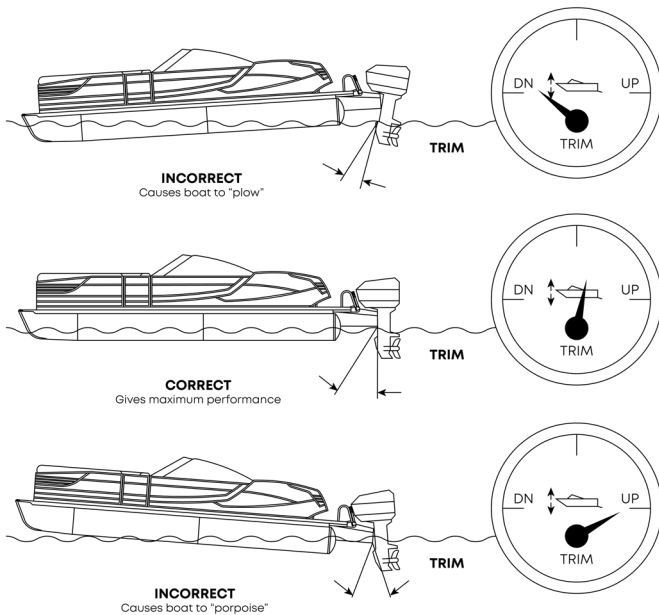

FIGURE 5-4 TRIMMING



Any passenger changing position while underway must be very careful to prevent injury or falling overboard. If passenger position must be changed, operator must first reduce speed.

At low idle speed, an outboard can be tilted up past trim range to permit operation in shallow water. However, the engine's cooling water intake holes must always remain submerged, otherwise the engine will overheat.



Use extreme caution when operating with drive unit raised. Cooling water intake holes must remain submerged. See owner's manual for details.

GENERAL RULES OF SEAMANSHIP

1. Cross waves at right angles.
2. When caught in heavy water or squalls, head either directly into the waves or at a slight angle. Reduce speed but maintain enough power to maneuver your boat safely.
3. Keep your speed under control. Respect the rights of boaters engaged in fishing, swimming, water skiing, or diving. Give them "wide berth." Never follow close behind a water skier.
4. When meeting a boat head-on, keep to the right whenever possible.
5. When two boats cross, the boat to starboard has the right of way.
6. When overtaking or passing, the boat being passed has the right of way. The boat being passed is required to maintain the same course and speed.

STOPPING

You cannot stop a boat as quickly as a land vehicle because a boat has no brakes. Stop the boat by allowing it to slow down to less than 5 miles per hour (8 km/h). Then, put the engine in reverse. By slowly increasing reverse power, you can stop the boat in a short distance. Remember that the boat does not respond to steering in reverse as well as it does when going forward.

ANCHORING

Anchor your boat if you stop for recreation or an emergency. The size and weight of your boat govern the weight of the anchor and the diameter of the anchor line. A burying anchor grips into the bottom and holds your boat secure. Holding power should be more important than weight. Your dealer can help you select the proper anchoring equipment

The length of the anchor line should be six to eight times the depth of the water to assure that the anchor bites into the bottom. The bottom end of the anchor line should be galvanized chain. The rest of the line should be nylon anchor line.

Keep anchor secure while underway to prevent damage or injury if boat's attitude changes suddenly. If your boat has a power winch, do not use it as the primary source for securing the anchor or anchor line. See the power winch instruction manual for details about proper operation and maintenance.

These are some general guidelines for anchoring your boat:

- Secure the anchor line to the deck cleat. Do not tie line to hardware not designed to support this stress.
- If you are anchoring for more than a few hours, use more than one anchor. If you use only one anchor, make sure your boat has enough space to swing full circle in case of shifting winds.
- Keep the anchor and line in an area where it will be readily available in an emergency.

Dropping Anchor

1. Have a crew member carefully lower the anchor, keeping a slight tension on the line as the anchor drops. Maintain tension after the anchor reaches the bottom. Simply throwing the anchor overboard usually fouls the line and requires starting over.
2. Maneuver the boat slowly aft until the proper length of line is run out.
3. Fasten the anchor line around the deck cleat. Anchor flukes should dig into the bottom and hold the boat in position.
4. Check shoreline landmarks when you drop anchor. Check the position of the landmarks again 30 minutes later. If your boat's position has changed, the anchor is dragging and must be reset.

Weighing Anchor

Weighing, or pulling in, the anchor requires moving the boat towards the anchor and pulling in the anchor line as the boat moves. When the line is vertical, pull up firmly on the anchor line to free the flukes from the bottom. If the anchor remains stuck, feed out a few feet of line and attach it to the bow cleat. Maneuver the boat around the anchor, keeping the line taut until you find an angle that will pull the anchor free.

DOCKING

Always approach the dock slowly. If possible, come in against the wind or current, whichever is stronger. Come in at a 30-45° angle. As the boat nears the dock, slowly swing parallel to it. If wind or current is moving toward the dock, move parallel to the dock further out. Let the wind or current push you in. Use extreme caution if wind or current is from your stern. Approach slowly at a slight angle with engine in slow reverse. Gently swing parallel. Tie stern first, then the bow.

If the weather looks bad, use spring-lines from the bow and stern to dock amidships of the boat. Tie up on the downwind side of the dock. If the wind is changeable, place fenders over the side between the boat and the dock.

MOORING

After you have positioned your boat next to the dock, you must secure it with mooring lines to keep it in position. Mooring lines must be long enough to secure your boat wherever it may be docked. For example, the length of the lines for a 20-foot (6.1 m) pontoon should be at least 19 feet (5.8 m). An eye splice at the end of each line works well with bow or stern cleats.

The mooring lines used most often are the bow line, the stern line, and spring-lines (Figure 5-5). Each line has a specific purpose. The bow line and the stern line secure your boat's bow and stern. The two spring-lines keep your boat from moving forward or backward when you are moored alongside a dock.

If you are mooring your boat for a short time, bow and stern lines may be the only lines you need. If you are mooring your boat for a longer time or the currents are swift, you should use spring-lines. The stern spring line leads from the boat's stern cleat forward to the piling or cleat on the dock. The bow spring-line leads from the bow cleat aft to the dock.

If you are mooring your boat in a slip, bow and spring lines, port and starboard, will keep your boat in position.

Attach mooring lines only to deck cleats or side rail mooring eyes. Do not attach mooring lines to any other part of the boat, such as railings, bimini top supports, or trailer safety eyes welded to the pontoons

Note: If tides are a consideration, be sure to leave slack in the lines to make up for the rise and fall of the water while your boat is docked.

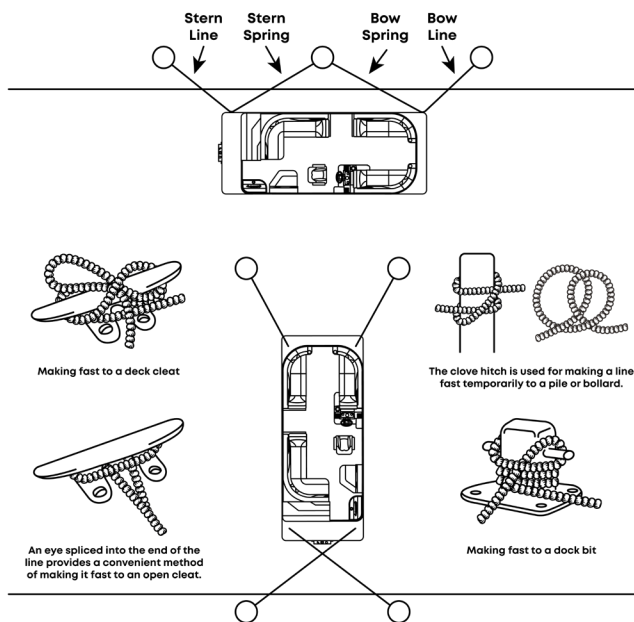

FIGURE 5-5 MOORING

PONTOON HOISTS AND LIFTS

The proper way to lift your boat out of the water is to use a hoist, or lift equipment, specifically designed for pontoon boats. This equipment is designed to support the entire boat structure and weight from the underside of the boat. Never attempt to lift your boat using any deck mounted hardware, or pontoon eyes, as this could cause structural damage. Never lift your boat with passengers aboard. Follow lift or hoist manufacturer's operating instructions.

EMERGENCY OPERATION

Boaters should respond to emergency calls if they are nearby and can help. You are expected to proceed to the scene and render assistance. Distress calls often are made for assistance with a disabled boat. A VHF marine radio (channel 16) is the best device for calling for help. Two international emergency signals are MAYDAY (life/death situation, request immediate assistance) and PAN PAN (safety of the boat or person in jeopardy).

The Federal Boat Safety Act of 1971 requires boat operators involved in accidents to offer aid to others in the accident and in emergencies. The law's "Good Samaritan" clause also absolves you from civil liability if your assistance causes bodily injury or property damage.

As a boat owner, you have accepted many responsibilities. You should know how to cope with any type of emergency that could occur on your boat or someone else's. There is a way to handle each emergency—if **you do not panic!** Proceed calmly using good common sense. Some tips for common situations are listed below.

Fire or Explosion

If a fire occurs, stop the boat immediately. Position the boat so that the fire is downwind. Boat fires involving flammable liquids, such as gasoline, can be extinguished with your dry chemical or carbon dioxide type extinguisher. Read the extinguisher directions and memorize them. Be prepared to use the extinguisher quickly if the need arises.

You must decide quickly whether to abandon ship or stay aboard and try to extinguish it. If the fire involves a trash container, smoldering upholstery or an electrical fire, try to extinguish the blaze by aiming the extinguisher nozzle at the base of the flame. However, a fire involving the fuel system greatly increases the danger of an explosion. If it is necessary to abandon ship, make sure all passengers wear a PFD or take it with them before going overboard.

Fire is an immediate danger after a gasoline vapor explosion. Gasoline floats on water and can spread out over the surface of the water. If you do abandon ship, keep yourself and your passengers clear of the burning boat.

Storms

Storms sometimes appear without advance notice. Although

weather information from meteorological observation and reporting stations is available, weather bureau predictions are sometimes wrong or information gathering equipment can fail. Many marinas fly weather signals. You should learn to recognize these signals and monitor your local weather forecasts before leaving port. Watch the horizon for indications of an approaching storm.

The present and forecasted weather conditions are of primary consideration, but a threat of possible storms should always be a concern. There is no substitute for a strong understanding of what action to take when the weather takes a turn for the worst. Return to a safe port if time allows. If it is impossible to do so, stow or tie down all loose gear and instruct everyone aboard to put on a PFD.

Fog

When warm air is above cooler water, its temperature drops. As the air cools, it loses its ability to hold moisture and fog develops when the air temperature drops to the dewpoint temperature. Dewpoint temperature depends on the amount of humidity in the air. You should be aware that fog can form quickly as the air temperature drops, especially if the air is calm and humid. Remember the following guidelines:

- Turn on navigation lights.
- Instruct everyone on board to put on a PFD.
- If your boat has depth finding equipment, take soundings and match them with soundings on your charts.
- Station a person in forward position on the boat as a lookout.
- Reduce your speed. From time to time, stop engine and listen for fog signals.
- Sound the horn at proper intervals to warn other boaters.
- If there is any doubt in continuing boat movement, anchor. Listen for other fog signals while continuing to sound the foghorn for a boat at anchor.

Man Overboard

If someone in your boat falls overboard, turn the steering wheel to move the propeller away from the person. Circle around quickly, approaching into the wind and waves. Turn off the engine when the person is alongside. If the person can grasp, throw them a line or extend a paddle or a boat hook within

their reach. Help the person back on board.

Do not dive over the side after an unconscious person or non-swimmer unless you are trained in lifesaving techniques. It is harder to save two people than one. If the victim has sunk out of sight, probe gently beneath the surface with a paddle or boat hook. Do not restart the engine until you have drifted clear of the victim's suspected location.

Collision

If you are involved in a collision with a boat, or with a fixed object such as a pier, sandbar, reef, or bridge, check for injuries and render first aid, if necessary. Before proceeding, check out your boat thoroughly. Check steering cables for possible jamming. Raise the motor and inspect for possible propeller or lower unit damage. Proceed carefully to port and remove the boat from the water to thoroughly inspect it for damage.

Running Aground

Operating in shallow water can present several hazards. Sand bars in narrow inlets are constantly shifting, making it difficult to mark them with buoys. Sometimes sand bars are indicated by waves as they form into breakers while passing over sand bars.



To prevent boat damage, DO NOT use deck hardware for towing. Use a commercial towing service.

If your boat runs aground, first check persons on board for injury. Then check for damage to the boat. It may be possible to rock the boat by shifting the weight of the passengers and gear and by raising the drive unit while reversing the engine. If you ground your boat on a sandbar, shut down the engine and seek help from another boater or radio for help. See your dealer as soon as possible, as sand ingested in the engine cooling system can cause major engine damage.

If the drive unit strikes an underwater hazard, check for boat and drive unit damage. Pontoons still float if they are punctured. Go at a slower speed. A water-logged pontoon may change handling characteristics. If the engine vibrates

excessively after striking an underwater obstruction, it may indicate a damaged propeller. If vibration is noticeable, return to port slowly to prevent further drive and engine damage from an out-of-balance condition. Watch the temperature gauge to make sure the engine does not overheat.

Caring for Your Boat

Proper care helps assure that your boat will continue to look like new after years of service. We recommend that maintenance and repairs be performed by your dealer. However, some owners may prefer to take care of routine maintenance and repairs themselves. For those individuals, this chapter includes general information and basic procedures.

When your boat is not in use, protect it from the elements by storing it inside, under a roof, with a mooring cover or playpen cover over it, or with furniture covers installed. Do not store your boat outside. Do not dock the boat under trees. Dirt, leaves, and other debris will accumulate on the floor and vinyl surfaces.

IMPORTANT: Check with your dealer before beginning any maintenance or repair if you are not sure about the proper tools, equipment, and supplies to be used.

Note: Always refer to the manufacturers' component manual for detailed maintenance and repair procedures. If information provided in this manual conflicts with information in the specific manufacturers' manual, that manual must take precedence.

ENGINE

Refer to the engine owner's manual for recommended frequencies and detailed information about engine care and maintenance. If you have operated the boat in shallow or saltwater, flush the engine with fresh water at the end of your boating excursion.

ALUMINUM SURFACES

Cleaning

Treat natural aluminum portions of aluminum boats with a clear protective coating to reduce natural oxidation. Rinse occasionally with clear water or mild detergent to keep these portions of the boat clean. Use water and mild detergent for cleaning and protect the surface with a liquid cleaner or wax. Do not use harsh chemicals or abrasives.

Remove stains or light corrosion with a good metal polish. Buff

only with a fine rubbing compound, if necessary. Remove algae, scum, or other marine growth while they are still wet. They are much harder to remove if they have had a chance to dry out.

Painting

Some anti-fouling paints react adversely with aluminum. Do not use paints or primers containing copper, mercury, or lead on aluminum boats, with or without primer. Ask your dealer to recommend the right paint and primer for your situation.

Corrosion

Modern boat building techniques minimize corrosion problems on aluminum models; nevertheless, galvanic corrosion can occur when dissimilar metals come in contact and are wetted by contaminated water. In general, saltier water leads to faster corrosion.

Stray current corrosion occurs when an electrical current escapes a metal protector for a water path, causing rapid corrosion. Other types of corrosion are salinity and pollution corrosion. Although we have used high quality marine aluminum to build your boat, we recommend that you take the following precautions to prevent corrosion:

1. Regularly rinse your boat's aluminum with fresh water.
2. Inspect the zinc anode on your boat's engine(s) frequently for deterioration. If you operate in salt, polluted, or brackish waters, inspect the anodes more frequently. A sacrificial anode will deteriorate before the metal it protects will deteriorate. If the zinc anode erodes 50% or more, replace it to continue protection against corrosion; otherwise, other metal parts may be damaged. Never paint zinc anodes. See your engine manual for more information about the zinc anodes on your boat.
3. Regularly inspect metal components that are in contact with the water. Look for pitting or a lacy appearance to the metal. If you see damage, inspect all wiring for breaks or loose connections.
4. Use a wood or rubber gasket when mounting non-aluminum fixtures or hardware to aluminum. Never use the aluminum on your boat as ground for an electrical circuit. To make sure accessories are properly grounded, run the ground wire directly to the negative post of the boat's battery.
5. Do not reverse polarity on any electrical device.

6. Never apply copper, lead, antimony, arsenic, or mercury based anti-fouling paint to your boat with or without a primer coat.
7. Have your dealer install sacrificial zinc anodes on your boat. Zinc anodes can help protect your boat from electrolytic corrosion caused by stray electric current, and from saltwater galvanic corrosion.
8. Have your dealer install a quality battery switch(es). Follow the switch manufacturer's operating instructions.

Note: There is danger of an electric current in the water near boats linked to shore power.

IMPORTANT: Do not attach copper, steel, brass, or bronze directly to the aluminum on your pontoon. Doing so may cause an electrolytic reaction. Use only aluminum or stainless steel or separate dissimilar metals with a gasket.

PONTOONS

If a rock, log, or other obstacle punctures a pontoon, it will not fill completely with water. If water enters a portion of the pontoon, the boat will list, but it will not sink. Repairing a punctured pontoon requires specialized welding skills. Contact your dealer for pontoon repairs.

SALTWATER USE

If your boat is in daily contact with saltwater, remove it from the water every three months and flush it from top to bottom with fresh water. In saltwater areas hardware should be flushed with fresh water. Clean hardware and spray with a marine corrosion inhibitor every month. Saltwater can also affect the engine. Contact your dealer or Crest Pontoons for additional information about using your boat in saltwater.

DECK COVERINGS

Several types of deck coverings are available on Crest pontoons. The following is a brief explanation of how to care for each type of covering. For more information, check the literature in your Owner's Packet or check with your Crest dealer.

Vinyl Decking

Clean vinyl decking regularly to maintain its beauty and

performance. Clean the decking using a medium-soft brush, warm water, vinyl cleaner, or mild soap. Rinse thoroughly and dry. Your dealer can help you select the right product. For information about stain removal, check the literature in your Owner's Packet.

DECK HARDWARE AND FITTINGS

Clean all cleats, rails, and similar equipment periodically with a good chrome cleaner and polish with paste wax to prevent corrosion. Replace broken or damaged hardware by bolting it through the deck with a reinforcing block underneath.

Use deck hardware only for its intended purpose. Do not use stanchions for tying off fenders, mooring lines, or fastening water ski ropes. A mooring cleat should not be used for a water ski rope if obstructions prevent it from swinging in a proper arc.

Sunlight and ozone eventually cause a loss of elasticity in rubber components. Inspect them frequently and replace them when signs of hardening or surface cracking are detected.

SEAT COVERINGS AND VINYL

The vinyl used on your boat requires routine care. See the cleaning and care instructions on pages 6.5 and 6.6 and in your Owner's Packet. Keep vinyl clean and dry to keep mildew from forming. Remove seat cushions and wipe dry after each use. In rainy weather, cover or remove cushions since seams can trap and absorb moisture. Store cushions in a dry, well-ventilated place. Keep the boat covered when not in use with the correct furniture covers and/or mooring cover. This will help protect against damage from the elements and/or water saturation (waterlogging). These damages are not covered under warranty.

Each week, wipe vinyl surfaces with a soft damp cloth and towel dry. For general purpose cleaning, use warm water with a mild dish soap. Gently scrub with a small, soft bristle brush. Rinse thoroughly and towel dry. To remove dirt build-up, use Final Finish Vinyl Cleaner®. Apply and let soak for approximately 10 minutes. Then scrub with a soft bristle brush. For specific stain removal information, refer to the Care and Cleaning card in your Owner's Packet.

Suntan lotion and insect repellents can stain vinyl quickly and cause vinyl surface to deteriorate. Remove these products

immediately after contact and wash area with a mild soap solution. Rinse and towel dry.

IMPORTANT: Harsh detergents, abrasives, bleach, and solvents can cause permanent damage to vinyl upholstery. Refer to manufacturer's instructions for recommended stain removal procedures.

Protect your vinyl from being ripped or torn. Mildew, or a condition known as pinking or yellowing, can occur in any vinyl openings, and this type of damage is not covered by your warranty.

VINYL UPHOLSTERY CLEANING AND CARE INSTRUCTIONS

The upholstery on your boat is made to withstand the effects of sun, heat, rain, and soiling under normal conditions. While your vinyl is made to withstand the elements, it is always important to care for it by keeping it clean. Many substances may stain your vinyl if left on over a period of time. Remember to remove any contaminant and clean vinyl immediately.

Follow the cleaning instructions on page 6.6. Do not use 409® Cleaner or any products with a silicone base.

MOORING AND FURNITURE COVERINGS

Keep your Crest pontoon in like-new condition with quality mooring and/or seat covers—not for use when towing. They'll help keep your furniture dry, protect against UV sunlight degradation, leaf stains, pollen stains and dramatically reduce your cleaning time! Remember that winter storage in snow and ice areas requires additional protection. Also note typical plastic tarps don't provide ventilation, and may promote mold, mildew or pink staining of your pontoon boat seats. This potential damage is not covered under warranty.

Certain household cleaners, powdered abrasives, steel wool and industrial cleaners can cause damage and discoloration and are not recommended. Dry cleaning fluids and lacquer solvents should not be used as they will remove the printed pattern and gloss. Waxes should be used with caution as many contain dyes or solvents that can permanently damage the protective coating.

CANVAS

Note: Your Crest pontoon is shipped with a bimini top. If you want additional canvas, discuss your needs with your dealer who will order the canvas for you.

The bimini top is an acrylic fabric or a vinyl fabric. It resists mildew, rot, and the weather. ("Canvas" in this section refers to the bimini tops and other enclosures available through your dealer.)

If canvas is wet, let it air dry before you store it. Never store canvas damp or wet. Provide proper ventilation to limit the possibility of mildew.

Keep canvas clean. Dirt and dust on canvas support the formation of mildew. To clean canvas, wet down all canvas material. Scrub with a soft bristle brush and a solution of mild soap and water. Never use a detergent or bleach on your canvas. Brush or sweep the underside of the top every two weeks. Spray with Lysol or other disinfectant to prevent mildew. Lubricate zippers with paraffin and snaps with petroleum jelly.

Clean plastic windows by flushing with clear water; after dirt is removed, use an appropriate window cleaner. Do not wipe dirt from dry plastics or use abrasives. The plastic can become permanently scratched or dulled.

FLOOR COVERINGS

Clean vinyl flooring with a diluted household cleaner and warm water. Apply with a scrub brush. Rinse thoroughly. See the cleaning and care instructions in your Owner's Packet.

FIBERGLASS

Keep these surfaces clean to prevent dirt from scratching and dulling the finish. Clean them with a mild detergent and water. Do not use abrasives! At least twice a year, apply a coat of wax after cleaning and buff with a soft cloth to bring back the original sheen. If the fiberglass surface has oxidized (appearing as a light, milky white film), you may want to use a rubbing compound before waxing. Your dealer can recommend a good commercial product to use.

On boats with fiberglass parts, hairline cracks caused by weathering, impact, or other factors may develop in the gel coat

or surface coating. Blisters and small gouges may also occur. Fiberglass and gel coat repair require professional training. These repair services are usually offered by your dealer. (They are not covered by your warranty.)

PONTOON MAINTENANCE

Use a commercial hull cleaner and a brush to remove algae or scum on the pontoon. They are easier to remove if they are not allowed to dry out. If your boat will remain in the water for more than three months, check with our dealer about the best bottom coating to use for preventing algae or scum buildup.

Winterization Storage

This chapter includes general information for winterizing and storing your boat after the boating season. Your dealer can advise you about preparing your boat for storage. Following the procedures in this section helps to extend the life of your boat and its equipment and simplifies fitting out after storage.

Ventilation is very important during storage. Indoor storage is ideal, especially in areas where ice and snow accumulate. Make sure the storage building has adequate ventilation. If you use outdoor storage facilities, cover your boat with a canvas cover. Provide ventilation to keep the boat from “sweating” by building a frame over the boat to support the canvas. Build the frame several inches wider than the boat so the canvas will clear the rails.

Before preparing your boat for winter storage, thoroughly check the condition of the boat, its systems, and equipment. Note any repairs needed. The need for repairs may become apparent during winterization. Decide when and how to have the repairs completed.

PREPARATION FOR STORAGE

Preparing your boat for winter storage is like routine exterior care. Refer to Chapter 6 for specific cleaning solutions and procedures.

Lifting Your Boat

The best way to lift your boat out of the water is to load it on your trailer (see Chapter 4 for instructions). If a trailer is not available, arrange to have a marina lift your boat out of the water. Workers at the marina know the proper way to lift your boat and have the proper equipment available. See your dealer if you have questions about lifting your boat.

IMPORTANT: Stainless steel eyelets or stainless steel U-bolts on pontoons are to be used only for mooring. Attaching lifting lines at these points will damage the pontoons. Never try to lift the pontoon by connecting to the aluminum eyelets on the ends of the pontoons. These are not lifting or mooring eyelets.

Pontoons

Scrape off any crusted marine growth and barnacles. Then scrub thoroughly to remove marine growth and scum. Check for dents and cracks and for loose or broken rivets. Make any necessary repairs.

Deck

Wash the deck and walkway surfaces. Clean all deck hardware with a good chrome cleaner, then apply one coat of rust inhibitor. Corrosion inhibitors are available from your dealer.

Remove all cushions and any other items that can hold moisture and cause mildew. Cushions may be left on board only if they can be propped up where air can circulate. If you leave life jackets and other safety equipment onboard, be sure to leave space around them for adequate air circulation.

Engine

Refer to the owner's manual for detailed information about preparing the engine for winter storage.

Batteries

Remove the batteries and store them in a location away from freezing temperatures. Batteries should be stored in a cool, dry place on a wooden pallet. Do not place batteries directly on concrete, brick, or dirt floors because the charge will be absorbed into the ground. Charge the batteries once a month or apply a continuous trickle charge while they are being stored.



Battery electrolyte can cause severe eye damage and burn your skin. Wear goggles, rubber gloves, and a protective apron when working with a battery. If electrolyte spills, wash area with a solution of baking soda and water.

Clean the outside of the battery case, terminals, and battery clamps with a baking soda and water solution. Do not allow solution to enter battery cells.

Clean battery posts and clamps with a piece of fine grit emery cloth. Use a light sanding motion when cleaning.

Apply a light coat of petroleum jelly to cover the ends of the battery cables.

Freshwater System

Remove water tank and drain. Make sure water supply hoses from the tank are drained.

Livewell

Remove the standpipe and allow all water to drain from the livewells. Run the livewell pump just long enough to ensure that all water is removed. Remove the livewell inlet hose and drain.

SUPPORTING YOUR BOAT DURING STORAGE

Your boat's trailer is the ideal support during storage because it supports the boat under the main frames. Loosen or remove all tie downs. Place blocks under the axles to keep tires away from the ground. Now is a good time to repack the trailer wheel bearings.

If your boat is not stored on the trailer, see your dealer or marina for proper storage procedures.

If you are storing your boat on a lift, make sure it is supported properly on the bulkheads of the pontoon. A bunk type support should support the entire length of the pontoon. A folding lift type should provide support to the entire length of the deck. Be sure to follow the lift manufacturer's instructions for proper storage.

IMPORTANT: Improper storage of your boat can cause boat damage that is not covered by the warranty.

FITTING OUT AFTER STORAGE

Fitting out is not difficult if the boat was properly prepared for storage. Before launching your boat, do not load unneeded equipment or personal items until the launch and final checkout are complete. For detailed information on recommissioning your boat's systems and equipment, refer to the owner's manual for each system or component.

1. Inspect, visually and by smelling, the fuel system and all associated components for proper connections, wear, leaks, or other damage and needed repair. Inspection of the fuel system is an important safety precaution.
2. Check propellers for proper installation and tightness. Clean propeller is necessary.

3. Inspect all life jackets, anchor lines, and other safety equipment for proper operation and physical condition. Repair or replace if necessary.
4. Check all safety equipment including flares, flags, fire extinguishers, and first aid kits. Replace equipment as necessary.
5. Check charge on battery. Recharge or replace if necessary.
6. Clean battery terminal posts and cable terminal with wire brush or bronze wool. Inspect all battery wiring. Repair or replace if necessary.
7. Install batteries and attach cables. After cable posts are tightened down, smear posts with petroleum jelly or marine grade grease to keep out air and acid. Check all wiring connections and contacts for corrosion and tightness.
8. Inspect all wiring for fraying, wear, loose connections, or other damage. Repair or replace if necessary.
9. Inspect all switches, controls, and other related equipment for proper operation. Repair or replace if necessary.
10. Test operation of navigational lights and other lighting inboard. Repair or replace as necessary.
11. Reinstall drain plug after coating threads with thread seal tape.
12. Check all steering controls, cables, and linkage for free operation.
13. Test run engine as directed in the equipment manuals.
14. Check that water intake for livewell pump is clear.

Helpful Information

BOATING REGULATIONS

The local sheriff marine patrol, local Coast Guard office, or state Department of Natural Resources is responsible for enforcing boating regulations. Their goal is to help the boating public. You are subject to marine traffic laws and the "Rules of the Road" for both federal and state waterways. You must stop, if signaled to do so by enforcement officers, and permit them to board, if asked. The "Rules of the Road" can be obtained from your local U.S. Coast Guard Unit or the United States Coast Guard Headquarters by calling (202) 512-1800 or faxing your request to (202) 512-2250, and asking for the publication titled "Navigational Rules, International-Inland."

Many pamphlets prepared by the Coast Guard are available. They explain signal lights, buoys, safety, international and inland regulations, and other information which goes beyond the scope of this manual. "Aids to Navigation" (U.S. Coast Guard pamphlet #123) explains the significance of various lights and buoys. Because of proposed alterations in buoys and markers, contact the U.S. Coast Guard to stay informed of changes.) Other pamphlets, including the "Boating Safety Training Manual" and "Federal Requirements for Recreational Boats," are also available from the U.S. Coast Guard Headquarters.

U.S. Coast Guard website: uscgboating.org

The spoken word "MAYDAY" is the international signal of distress. MAYDAY should NEVER be used unless there is grave or imminent danger, and you need immediate assistance.

RULES OF SEAMANSHIP

Right-of-Way

In general, boats with less maneuverability have right-of-way over more agile boats. You must stay out of the way of the following vessels:

- A vessel not under command or aground. Due to their circumstances, these vessels have no maneuverability.
- A vessel restricted in its maneuverability. These vessels are performing work which limits their maneuverability such

as: surveying, dredging, laying pipe or cable, or servicing navigational markers among others.

- A vessel engaged in fishing. These include boats fishing with lines, trawls, or nets; but not trolling lines.
- Sailboats. Sailboats have the right-of-way over power boats; however if a sailboat is using a propeller to move forward, it is considered a power boat even if the sails are up.

Meeting Head-On

When two boats meet head-on, neither boat has the right-of-way. Both boats should decrease speed and pass sides port to port. However, if both boats are on the left side of a channel; each vessel should sound two short horn blasts and pass starboard to starboard. See Figure 8-1.

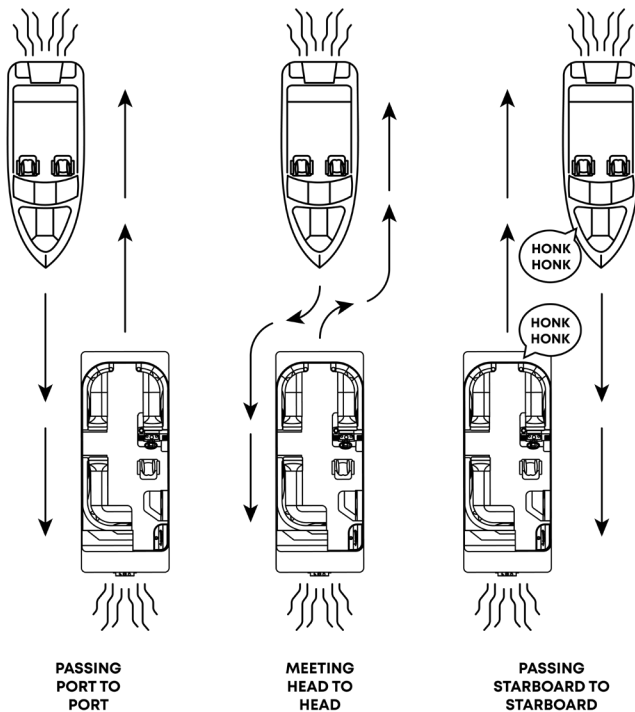

FIGURE 8-1 MEETING HEAD-ON

Crossing Situations

In a crossing situation, the boat on the right from the 12-4 o'clock position has the right-of-way. It must hold course and speed. The boat without right-of-way must keep clear and pass to the stern. See Figure 8-2.

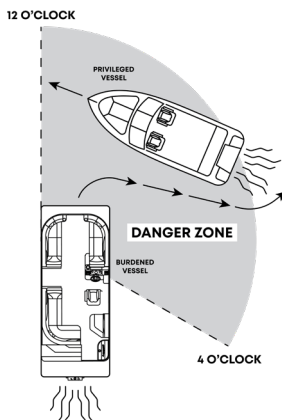

FIGURE 8-2 CROSSING

Overtaking

The boat overtaking the one ahead must yield the right-of-way to the boat being passed. The overtaking boat must make any necessary adjustments to keep out of its path. The boat being passed should hold its course and speed. See Figure 8-3.

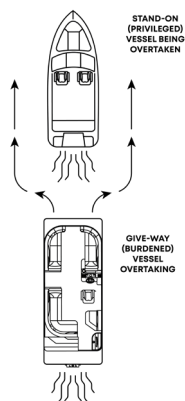

FIGURE 8-3 OVERTAKING

The General Prudential Rule

The general prudential rule regarding right-of-way is that if a collision appears unavoidable, neither boat has right-of-way. As prescribed in the Rules of the Road, both boats must act to avoid collision.

Night Running

Boats operating between sunset and sunrise (hours vary by state), or in conditions of reduced visibility, must use navigational lights. Nighttime operation, especially during bad

weather or fog, can be dangerous. All Rules of the Road apply at night, but it is best to slow down and stay clear of all boats regardless of who has right-of-way.

To see more easily at night, avoid bright lights when possible. Also, it is helpful to have a passenger keep watch for other boats, water hazards and navigational aids. Do not turn on docking or exterior courtesy lights while underway.

To determine the size, speed, and direction of other vessels at night, you should use the running lights. A green light indicates the starboard side, and a red light indicates the port side. Generally, if you see a green light, you have the right-of-way; if you see a red light, give way to the other vessel. See Figure 8-4.

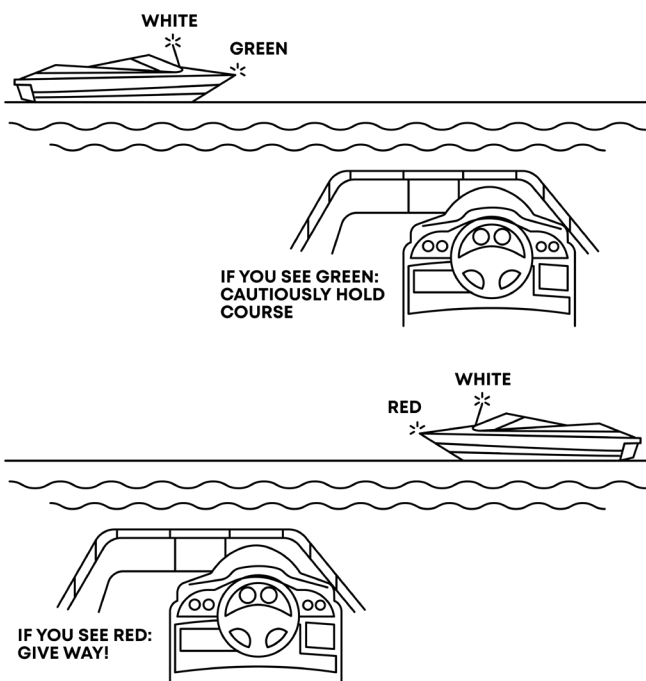

FIGURE 8-4 NIGHT RUNNING

Whistle Signals

Out on the water, whistle signals are commonly used. Although using a whistle signal is not necessary every time a boat is nearby, operators must signal their intentions when necessary

to avoid potentially confusing or hazardous situations. Use whistle blasts early enough to be noticed and understood by other boaters.

It is customary for the "standon" or privileged boat to signal first and the give way or burdened boat to return the same signal to acknowledge she understands and will comply.

Use the danger signal (five or more short and rapid blasts) if intent is not clear. A short blast is 1 or 2 seconds long. A long blast is 4 to 6 seconds long. The Navigational Aids Chart at the end of this chapter lists the meanings of the various whistle signals.

RECOMMENDED READING

We recommend that you read the boating literature published by your state boating agency and the U.S. Coast Guard. Other suggested reading includes the following:

United States Coast Guard Auxiliary. Boating Skills and Seamanship. LC74-164688. (illus.) (ISBN 0-930028-00-7). U.S. Coast Guard.

Bottomley, Tom. Boatman's Handbook. (illus.). 316 p. pap. (ISBN 0-688-03925-1, Hearst Marine Bk.) Morrow.

Chapman, Charles F. and Maloney, E.S. Chapman's Piloting, Seamanship and Small Boat Handling. (illus.) 62 p. (ISBN 0-87851-814-2, Pub. by Hearst Bks.); deluxe ed. (ISBN 0-87851-815-0). Morrow.

CONTACTS

There are many good boating publications that have information about your area and what other boats are doing, such as clubs and other activities. Education programs are sponsored by publications and organizations such as the U.S. Power Squadron, U.S. Coast Guard Auxiliary, and The American Red Cross. See your dealer about special courses available in your area. For detailed information contact:

American Red Cross

Local address (see local telephone directory)

Boat U.S. Foundation for Boating Safety Hotline

1-800-336-BOAT

1-800-245-BOAT (in Virginia)

Coast Guard Boating Safety Hotline
1-800-368-5647

NMMA Sources of Waterways Information – National Marine Manufacturers Association has five (5) booklets which list sources for safety, cruising, and local waterway information. Each covers a different region of the U.S. (North Central, South Central, Northeastern, Southeastern, and Western). For single copies, write Sources of Waterways Information, NMMA, 401 N. Michigan Avenue, Chicago, Illinois 60611. Ask for the booklet for your region.

United States Coast Guard Auxiliary
Local Flotilla or contact appropriate Coast Guard District
Headquarters

United States Power Squadron
P.O. Box 30423
Raleigh, NC 27617

NAVIGATIONAL AIDS

Aids to navigation (ATONS) help you to travel safely on the water. They help you get from one place to another and are most helpful if you have a nautical chart.

IMPORTANT: NEVER tie your vessel to an ATON. It is illegal because your boat blocks the ATON from the view of other boaters. Decreased visibility can contribute to a serious accident which may result in property damage, personal injury, or death.

Navigational Aids Chart

The illustrated Navigational Aids Chart located on the next two pages contain information concerning whistle signals, storm warnings, bridge signals, and buoy descriptions and information. It is your responsibility, as a safe boater, to be able to identify these navigational aids, to recognize their importance, and to learn about these aids to navigation and use this information while boating.

Regulatory markers are either signs or buoys. Signs are square with orange borders. Regulatory buoys are white and shaped like cylinders. They have horizontal orange bands near their tops and just above the water's surface. An orange circle on a marker means a controlled area. A message such as "No Wake, Idle Speed, No Skiing, or 5 MPH" may appear on the marker. An orange diamond means danger. If the diamond has an orange

cross inside it, don't enter the area. The reason you should stay out, such as "Swim Area" may be printed in black on the marker.

A Special Sign

In Florida, you may see a special sign: "Caution, Manatee Area." When you see this sign, slow down to idle speed. Manatees, an endangered species, are passive, large, slow-moving mammals. Many manatees are seriously injured or killed each year by boat propellers.

NAVIGATIONAL AIDS CHART

REMEMBER THESE RULES

1. OVERTAKING - PASSING: Boat being passed has the right-of-way. KEEP CLEAR.
2. MEETING HEAD ON: Keep to the right.
3. CROSSING: Boat on right has the right-of-way. Slow down and permit boat to pass.

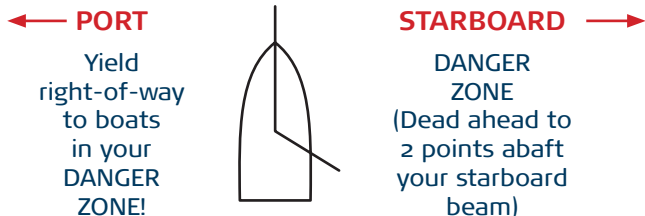

WHISTLE SIGNALS

ONE LONG BLAST: Warning signal (Coming out of slip)

ONE SHORT BLAST: Pass on my port side

TWO SHORT BLASTS: Pass on my starboard side

THREE SHORT BLASTS: Engine(s) in reverse

FIVE OR MORE BLASTS: Danger signal

BRIDGE SIGNALS

SOUND

VESSEL: Open 

BRIDGE: OK 

No 

VESSEL: Replies: 

RADIO: VHF CH. 13

VISUAL

VESSEL: Open 

BRIDGE: OK

No  

DAY (Flag)

NIGHT (Lights)

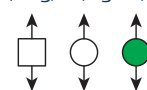

Same

Same

STORM WARNINGS



RED FLAG
Small boat
(Winds to 33 knots)



2 RED FLAGS
Gale
(Winds to 47 knots)



SQUARE RED FLAG BLACK BOX
(Storm)



2 SQUARE RED FLAGS BLACK BOX
(Hurricane)

LATERAL AIDS AS SEEN ENTERING FROM SEAWARD

PORT SIDE ODD NUMBER AIDS

■ GREEN LIGHT ONLY

FLASHING

OCCULTING

QUICK FLASHING

ISOPHASE

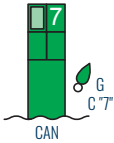
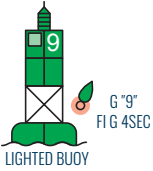

SAFE WATER MID-CHANNELS OR FAIRWAYS NO NUMBERS-MAY BE LETTERED

□ WHITE LIGHT ONLY MORSE CODE

Mo(A)

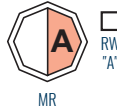

PREFERRED CHANNEL NO NUMBERS-MAY BE LETTERED

COMPOSITE GROUP FLASHING (2+1)

STARBOARD SIDE EVEN NUMBER AIDS

■ RED LIGHT ONLY

FLASHING

OCCULTING

QUICK FLASHING

ISOPHASE

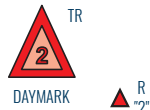

■ GREEN LIGHT ONLY

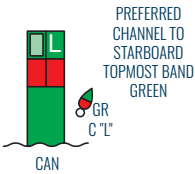
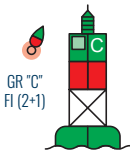

LIGHTED

■ RED LIGHT ONLY

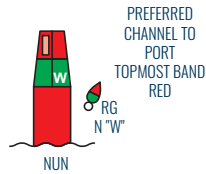
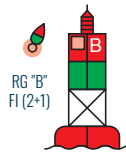

Boating Terminology

Abaft	Toward the stern.
Abeam	Amidships, at a right angle to the keel.
Aboard	On, in, or into a boat.
ABYC	American Boat and Yacht Council, Inc., the organization that sets voluntary safety and construction standards for small boats in the USA.
Adrift	Without motive power and without anchor or mooring.
Afloat	On the water.
Aft	Describing the after section of a vessel or things to the rear of amidships and near the stern.
Aground	Touching bottom.
Amidships	In the center, the center portion of a vessel.
Anchor	A forging or casting shaped to grip the sea bottom and, by means of a cable or rope, hold a boat in a desired position.
Anchorage	A customary, suitable, and (usually) designated harbor area in which vessels may anchor.
Astern	Toward the stern. An object that is aft of a boat is said to be astern of the boat.
Athwart	Across.
Aweigh	Off the bottom, said of an anchor.
Aye	Yes, while aboard a boat or ship. Means "I understand."

Bail (Bale)	To remove water from a boat by pump or bailer.
Ballast	Heavy material such as iron, lead, or stone placed in the bottom of the vessel.
Beacon	A post or buoy placed over a shoal or bank to warn vessels. Also, a signal mark on land.
Beam	Imaginary line amidships at right angles to keel of vessel. Also, vessel's width amidships.
Bearing	The direction or point of the compass in which an object is seen.
Belay	To make fast to a cleat or belaying pin; to cancel an order.
Below	Beneath or under the deck. One goes below when going down into the cabin.
Bend	To fasten by means of a bend, or knot.
Berth	A position, as a place to sleep or in which a vessel may be made fast; a margin of safety, as "a wide berth."
Bilge	The lower internal part of a boat's hull.
Bollard	A strong post for holding lines fast.
Bow	The forward part or front of the boat.
Breakers	Waves cresting as they reach shallow water, or on a beach.
Breakwater	A structure, usually stone or concrete, built to create a harbor or improve an existing one.
Bulkhead	Vertical partition in a boat.
Burdened Vessel	Former term for the vessel which must stay clear of vessels with the right-of-way.

Calking (Caulking)	Forcing filler material into the seams of the planks in a boat's deck or sides to make them watertight.
Camber	The arch of a deck sloping downward from the center toward the sides.
Capsize	To turn over.
Carburetor Backfire Flame Arrestor	Required equipment on all motorboats except outboards and diesels. Reduces chance of fire caused by backfires in internal combustion engines.
Cardinal Points	The four main points of a compass: north, east, south, and west.
Ceiling	The inside lining of the hull.
Certificate	Government paper, such as a boat's license.
Chart	A map of a body of water that contains piloting information.
Chine	The intersection of sides and bottom of a boat.
Cleat	A piece of wood or metal with projecting ends to which lines are made fast.
Clinker	A method of planking in which the lower edge of each strake overlaps the upper edge of the strake next below. (Also called lapstrake.)
Coaming	A raised edge, as around part or all of a cockpit, that prevents seawater from entering the boat.
Coast Guard	The federal marine law enforcement and rescue agency in the U.S.
Cockpit	A well or sunken space in the afterdeck of a small boat for the use of the helmsman and crew.
Companionway	A hatch or entrance from deck to cabin.

Compass	The instrument that shows the heading of a vessel.
Cowls	Hooded openings used for ventilation.
Cradle	A frame used to support a vessel on land.
Current	The movement of the water in a horizontal direction.
Deadrise	The rise of the bottom of a midship's frame from the keel to the bilge.
Deck	Any permanent covering over a compartment.
Deep-six	To discard or throw overboard.
Depth Sounder	An electronic depth-finding instrument measuring the time a sound wave takes to go from the vessel to the bottom and return, then displaying the result in feet, fathoms, or meters.
Dinghy	A small, open boat.
Displacement Hull	Type of hull that plows through the water even when more power is added.
Dock	An enclosed or nearly enclosed water area; all the port installations; a place where vessels can moor, as a pier, wharf, or floating dock.
Documented Vessel	Vessel registered with the U.S. Coast Guard.
Dolphin	A small group of piles in the water generally used for mooring or as a channel marker.
Draft	The depth of the vessel below the water line measured vertically to the lowest part of the hull.

Dunnage	Mats, boughs, pieces of wood, or other loose materials placed under or among goods carried as cargo in the hold of a ship to keep them dry and to prevent their motion and chafing; cushioning or padding used in a shipping container to protect fragile articles against shock and breakage; baggage or personal effects.
Ebb	An outgoing tide.
Estuary	An inlet or arm of the sea.
Fathom	Six feet.
Fenders	Objects placed along the side of the boat to protect the hull from damage.
Flare	The outward spread of the boat's sides from the waterline to the rail at the bow. Also, a pyrotechnic signaling device that can indicate distress.
Fore	Used to distinguish the forward part of a boat or things forward of amidships. It is the opposite of aft or after.
Forward	Toward the bow.
Frame	Ribs of the hull extending from the keel to the highest continuous deck.
Freeboard	The vertical distance measured on a boat's side from the waterline to the gunwale.
Galley	The kitchen area of a boat.
Gimbals	Swivels used to keep equipment level.
Give-Way Vessel	The one which must stay clear of vessels which have the right-of-way.
Grab Rail	A convenient grip on a cabin top or along a companion ladder.
Gunwale	The upper edge of a boat's side. (Pronounced gunnel.)

Harbor	A safe anchorage protected from most storms; may be natural or man-made, with breakwaters and jetties; a place for docking and loading.
Hatch	An opening in a boat's deck for persons or cargo to go below.
Head	A marine toilet.
Headway	Forward motion of a vessel through the water.
Helm	The wheel or tiller by which a ship is steered.
Holding Tank	Storage tank for sewage so that it will not be pumped overboard into the water.
Hull	The body of a boat.
Hypothermia	A physical condition where the body loses heat faster than it can produce it.
Inboard	More toward the center of a vessel; inside; a motor fitted inside the boat.
Inland Rules	Rules of the road that apply to vessel operation in harbors and certain rivers, lakes, and inland waterways.
Intracoastal Waterways	(ICWs): bays, rivers, and canals along the coasts (such as Atlantic and Gulf of Mexico coasts) connected so that vessels may travel without going into the open sea.
Jetty	A structure, usually masonry, projecting out from the shore; a jetty may protect a harbor entrance.
Keel	The permanently positioned fore and aft backbone member of a boat's hull.
Knot	To bend a line. Also, a unit of speed equal to one nautical mile (6,076.10 feet) an hour.

Launch	(1) To put a vessel into the water; (2) A small open powerboat mainly used for transportation between a vessel and shore.
Lee	The side opposite to that from which the wind blows.
Leeward	Situated on the side turned away from the wind. (Opposite of windward.)
Leeway	The amount a boat is carried sideways by the wind's force or current.
Limber Holes	Drainage holes in the bilge timbers of a vessel allowing water to run to a low point for pumping out.
List	(1) A continuous leaning to one side often caused by an imbalance in stowage or a leak into one compartment; (2) A light list is a printed listing of aids to navigation in geographical order; or inclining of a vessel toward the side.
LOA	Length overall; the maximum length of a vessel's hull, excluding projecting spars or rudder.
Locker	A storage place, a closet.
Log	A record or diary of a vessel's journey.
Lubber's Line	A mark or permanent line on a compass that shows the course of the boat.
Making Way	Making progress through the water.
Marina	A place, essentially a dock area, where small recreational boats are kept; usually where floats or piers as well as service facilities are available.
MAYDAY	A radio distress call from t h e French m'aidez (help me); SOS in Morse Code.

Mooring	Commonly the anchor chain, buoy, pennant, etc., by which a boat is permanently anchored in one location.
Motor	A source of mechanical power.
Motorboat	Any watercraft 65 feet or less in length propelled by machinery, whether or not such machinery is the principal source of propulsion.
Navigation	The art of conducting a ship from port to port.
Nautical Mile	6076.12 feet, or 1852 meters, an international standard; the geographical mile, the length of one minute of latitude at the equator, is 6087.20 feet.
Nun Buoy	A conical, red buoy bearing an even number and marking the starboard side of a channel from seaward.
Oar	A long, wooden instrument with a flat blade at one end used for propelling a boat.
Outboard	(1) A propulsion unit for boats attached at the transom; includes motor, drive shaft, and propeller; fuel tank and battery may be integral or installed separately in the boat; (2) Outside or away from a vessel's hull; opposite of inboard.
Outdrive	A propulsion system for boats with an inboard motor operating an exterior drive with drive shaft, gears, and propeller; also called stern drive and inboard/outboard.
Overall Length	The extreme length of a vessel, excluding spars or rigging fittings. See LOA.
Painter	A rope attached to the bow of a boat for making it fast.

PFD	Personal Flotation Device.
Pier	A structure, usually wood or masonry, extending into the water and used as a landing place for boats and ships.
Pile	A vertical wooden or concrete pole driven into the bottom; may be a support for a pier or floats; also used for mooring.
Piling	A structure of piles.
Pitch	(1)The up and down movement as the bow and stern rise and fall due to wave action; (2) The theoretical distance advanced by a propeller in one revolution.
Planing Hull	Type of hull that is shaped to lift out of the water at high speed and ride on the surface.
Port	The left side of a boat when you are facing the bow. Also, a destination or harbor.
Privileged Vessel	Former term for the vessel with the right-of-way.
Propeller	Wheel or screw mechanism that pushes water aft to propel the boat.
Rigging	The general term for all lines (ropes) of a vessel.
Roll	The sideward motion of a boat caused by wind or waves.
Rules of the Road	The nautical traffic rules for preventing collisions on the water.
Scope	The length of the anchor rope or chain; 6 to 1 scope means that the length of the anchor rope from the boat to the anchor is 6 times the depth of the water.

Scupper	A hole allowing water to run off the deck.
Sea Anchor	A floating canvas cone held open by wire rings with an opening in the smaller end and a rope bridle at the larger end attached to a line leading to the vessel; used in storm conditions to (a) keep the bow of the boat to the wind, and (b) slow downwind drift of the boat.
Seacock	A thru-hull valve; a shutoff on a plumbing or drainpipe between the vessel's interior and the sea.
Slip	(1) A berth for a boat between two piers or floats; (2) The percentage difference between the theoretical and the actual distance that a propeller advances when turning in water under load.
Sole	The cabin or cockpit floor.
Spar Buoy	A channel marker that looks like a tall, slender pole.
Stand-On Vessel	The vessel with the right-of-way.
Starboard	The right side of a boat when you are facing the bow.
Stern	The after end or back of the boat.
Stow	To store items neatly and securely.
Strake	Planks running fore and aft on the outside of a vessel.
Taffrail	The rail around a boat's stern.
Tide	The alternate rise and fall of waters caused by the gravitational attraction of moon or sun.
Topsides	(1) The sides of a vessel above the waterline; (2) On deck as opposed to below deck.

Transom	The transverse planking which forms the after end of a small, square-ended boat. (Outboard motors are usually attached to a transom.)
Trim	To arrange weights in a vessel in such a manner as to obtain desired draft at bow and stern.
Trimaran	Boat with three hulls—the center one is the largest.
Unbend	To cast off or untie.
Underway	Vessel in motion, i.e., when not moored, at anchor, or aground.
USPS	United States Power Squadron, a private membership organization that specializes in boating education and good boating practices.
Vessel	Every kind of watercraft, other than a seaplane on the water, capable of being used as a means of transportation on water.
VHF Radio	A Very High Frequency electronic communications and direction-finding system.
Wake	Moving waves created by vessel motion. Track or path that a boat leaves behind it when moving across the water.
Wash	The loose or broken water left behind a vessel as it moves along; the surging action of waves.
Waterline	The intersection of a vessel's hull and the water's surface; the line separating the bottom paint and the topsides.

Warranty Transfer

HOW TO REQUEST WARRANTY SERVICE

To request service under this Limited Warranty, take your boat during the applicable warranty period to any authorized Dealer, and describe in detail or set forth in writing the specific nature of the perceived defect. Please visit crestpontoonboats.com to locate the authorized Dealer closest to you.

If qualifying for service under this limited warranty, the dealer will inform you whether the repair work will be performed at the dealer's location or at the factory. Crest Pontoons shall have the absolute and sole discretion to select the appropriate location for the warranty work and method of repair. You are solely responsible for all costs associated with transporting your boat to and from the authorized Dealer and repair facility.

What Will We Do?

For any defect qualifying for service under this Limited Warranty, Crest Pontoons will elect (in our sole and absolute discretion) to either repair or replace the defective part or component.